



*Fédération
Aéronautique
Internationale*

Indoor Skydiving Competition Rules

For
Dynamic 2-way and Dynamic 4-way

2017 Edition
Effective 1st March 2017

*Maison du Sport International
Av. de Rhodanie 54
CH-1007 Lausanne
Switzerland
Tél. +41 (0)21 345 10 70
Fax +41 (0)21 345 10 77
E-mail: info@fai.org
Web: www.fai.org*

FEDERATION AERONAUTIQUE INTERNATIONALE

MSI - Avenue de Rhodanie 54 – CH-1007 Lausanne - Switzerland

Copyright 2017

All rights reserved. Copyright in this document is owned by the Fédération Aéronautique Internationale (FAI). Any person acting on behalf of the FAI or one of its Members is hereby authorized to copy, print, and distribute this document, subject to the following conditions:

- 1. The document may be used for information only and may not be exploited for commercial purposes.**
- 2. Any copy of this document or portion thereof must include this copyright notice.**
- 3. Regulations applicable to air law, air traffic and control in the respective countries are reserved in any event. They must be observed and, where applicable, take precedence over any sport regulations.**

Note that any product, process, or technology described in the document may be the subject of other Intellectual Property rights reserved by the Fédération Aéronautique Internationale or other entities and is not licensed hereunder.

RIGHTS TO FAI INTERNATIONAL SPORTING EVENTS

All international sporting events organised wholly or partly under the rules of the Fédération Aéronautique Internationale (FAI) Sporting Code¹ are termed *FAI International Sporting Events*². Under the FAI Statutes³, FAI owns and controls all rights relating to FAI International Sporting Events. FAI Members⁴ shall, within their national territories⁵, enforce FAI ownership of FAI International Sporting Events and require them to be registered in the FAI Sporting Calendar⁶.

An event organiser who wishes to exploit rights to any commercial activity at such events shall seek prior agreement with FAI. The rights owned by FAI which may, by agreement, be transferred to event organisers include, but are not limited to advertising at or for FAI events, use of the event name or logo for merchandising purposes and use of any sound, image, program and/or data, whether recorded electronically or otherwise or transmitted in real time. This includes specifically all rights to the use of any material, electronic or other, including software, that forms part of any method or system for judging, scoring, performance evaluation or information utilised in any FAI International Sporting Event⁷.

Each FAI Air Sport Commission⁸ may negotiate agreements, with FAI Members or other entities authorised by the appropriate FAI Member, for the transfer of all or parts of the rights to any FAI International Sporting Event (except World Air Games events⁹) in the discipline¹⁰, for which it is responsible¹¹ or waive the rights. Any such agreement or waiver, after approval by the appropriate Air Sport Commission President, shall be signed by FAI Officers¹².

Any person or legal entity that accepts responsibility for organising an FAI Sporting Event, whether or not by written agreement, in doing so also accepts the proprietary rights of FAI as stated above. Where no transfer of rights has been agreed in writing, FAI shall retain all rights to the event. Regardless of any agreement or transfer of rights, FAI shall have, free of charge for its own archival and/or promotional use, full access to any sound and/or visual images of any FAI Sporting Event. The FAI also reserves the right to arrange at its own expense for any and all parts of any event to be recorded.

-
- 1 FAI Statutes, Chapter 1, para 1.6
 - 2 FAI Sporting Code, Gen. Section, Chapter 4, para 4.1.2
 - 3 FAI Statutes, Chapter 1, para 1.8.1
 - 4 FAI Statutes, Chapter 2, para 2.1.1; 2.4.2; 2.5.2 and 2.7.2
 - 5 FAI By-Laws, Chapter 1, para 1.2.1
 - 6 FAI Statutes, Chapter 2, para 2.4.2.2.5
 - 7 FAI By-Laws, Chapter 1, paras 1.2.2 to 1.2.5
 - 8 FAI Statutes, Chapter 5, paras 5.1.1, 5.2, 5.2.3 and 5.2.3.2
 - 9 FAI Sporting Code, Gen. Section, Chapter 4, para 4.1.5
 - 10 FAI Sporting Code, Gen. Section, Chapter 2, para 2.2.
 - 11 FAI Statutes, Chapter 5, para 5.2.3.3.7
 - 12 FAI Statutes, Chapter 6, para 6.1.2.1.3

INTENTIONALLY LEFT BLANK

This document takes effect on the 1st of March 2016.

<i>TABLE OF CONTENTS</i>	<i>Page</i>
Chapter 1: FAI Authority	2
1.1 FAI authority	2
Chapter 2: Definitions of Words and Phrases Used in these Rules	2
2.1 Team	2
2.2 Body	2
2.3 Heading	2
2.4 Move	2
2.5 Pattern, Compulsory Pattern	2
2.6 Sidelines	2
2.7 Centreline	2
2.8 Ring	2
2.9 Anti-Chamber	2
2.10 Diffuser	2
2.11 Flight	2
2.12 Routine	2
2.13 Battle	2
2.14 Working Time	2
Chapter 3: The Events.....	2
3.1 Discipline	2
3.2 Objective of the Events	2
3.3 World Champions.....	2
Chapter 4: General Rules	3
4.1 Equipment	3
4.2 Wind Tunnel Equipage	3
4.3 Speed Setting and Training Flights	3
4.4 Draw & Freefall.....	3
4.5 Order of Flights.....	4
4.6 Flight Chamber Entry	4
4.7 Re-flights	4
Chapter 5: Rules Specific to the Event	4
5.1 Teams.....	4
5.2 Routines	4
5.3 Number of Rounds	4
5.4 Order of Routines	4
5.5 Battles	4
5.6 Qualification Rounds	4
5.7 Tournament	5
Chapter 6: Judging and scoring	5
6.1 General.....	5
6.2 Scoring Free Routines.....	5
6.3 Scoring Speed Routines	6
6.4 Scores and Results	7
6.5 Judging Rules.....	7
Chapter 7: Rules Specific to the Competition	7
7.1 Composition of Delegations	7
7.2 Competition Schedule	8
Annexes	8
Addendum A1 – Speed Routine Compulsory Patterns - Snakes.....	9
Addendum A2 – Speed Routine Compulsory Patterns - Verticals	11
Addendum A3 – Speed Routine Compulsory Patterns - Mixers	14
Addendum B – Basic Orientations, Rotations and Pathways	18
Addendum C – Difficulty	20
Addendum D – Free Routine Description.....	23
Addenda E – Tournament Brackets	25

1. FAI Authority

- 1.1. The competition will be conducted under the authority granted by the FAI, according to the regulations of the Sporting Code of the FAI, General Section, and Section 5 as approved by the IPC and validated by the FAI, and these rules. All participants accept these rules and the FAI regulations as binding by registering in the competition.

2. Definitions of Words and Phrases used in these Rules

- 2.1. A Dynamic 2-way (D2W) Team is comprised of two (2) Performers.
A Dynamic 4-way (D4W) Team is composed of four (4) Performers plus one (1) Alternate.
- 2.2. Body: a body consists of the entire Performer and his/her equipment.
- 2.3. Heading: the compass direction in which the front of the torso of the Performer faces.
- 2.4. Move: a change in body position, and/or a rotation around one or more of the three (3) body axes, or a static pose. See Addendum B.
- 2.5. Pattern: a movement sequence during which the Performers' bodies follow pathways, often with embedded moves or intermixing.
- 2.5.1. Compulsory Pattern: a Pattern with specific performance requirements. See Addenda A.
- 2.6. Sidelines (for Speed Routines): two (2) vertical lighted lines positioned on the transparent tunnel walls 180° opposite each other to describe a vertical plane that spans across the flight chamber. The start Sideline is clockwise from the doorway (with respect to top view.)
- 2.7. Centreline: a vertical plane that spans across the centre of the flight chamber extending from one (1) vertical line positioned on the transparent tunnel wall 90° offset from the two (2) vertical lighted lines.
- 2.8. Ring (for Speed Routines): a horizontal line that crosses the centre of the flight chamber, two (2) metres above the cable floor, between the two (2) Sidelines.
- 2.9. Anti-Chamber: area used by Teams as a waiting area for entrance into the flight chamber. This area is separated from public viewing areas and is the exclusive use for Teams on call.
- 2.10. Diffuser: that vertical part of the flight chamber above the transparent viewing section.
- 2.11. Flight: a Team's performance in the flight chamber.
- 2.12. Routine: a sequence of Moves or Patterns performed during the working time.
- 2.12.1. Speed Routine: a routine composed of three (3) randomly drawn Compulsory Patterns (one from each group, Snakes, Verticals and Mixers, in that order), repeated three (3) times, in the fastest time possible. The Speed Routine starts with a compulsory entrance and ends with a compulsory exit sequence.
- 2.12.2. Free Routine: a routine composed of Moves and/or Patterns chosen entirely by the Team.
- 2.13. Battle: two (2) Teams compete against each other performing either a Free Routine or Speed Routine. One (1) Team wins each Battle. (Battles may consist of more than two Teams, as shown in Addenda E.)
- 2.14. Working Time: the period of time during which a Team may perform a routine during a flight. Working time starts the instant that the Timing Judge gives the Team a visual signal to start.
- 2.14.1. Speed Routine Working Time ends when the last Performer completely exits the doorway of the flight chamber, as determined by the Timing Judge or by laser technology.
- 2.14.2. Free Routine Working Time:
 - D2W Free Routine: Working Time is 60 seconds.
 - D4W Free Routine: Working Time is 90 seconds.
At the end of the Free Routine working time, a visual signal will be given and the Team will have 15 seconds to exit the flight chamber, if they have not already exited.

3. The events

- 3.1. Discipline: The discipline comprises Dynamic 2-way (D2W) and Dynamic 4-way (D4W). There is no gender separation.
- 3.2. Objective of the Events: The objective for the Team is to perform Free Routines with the highest possible merit and Speed Routines in the fastest possible time.
- 3.3. World Champions:
- 3.3.1. After all completed Rounds and Battles, World Champions in D2W and D4W, will be declared.
- 3.3.2. The D2W World Champions and the D4W World Champions are the Teams winning the top Battle of their event.

- 3.3.2.1.** Ties: If two (2) Teams Battling each other each won a Battle in the last round of the Tournament, for 1st and 2nd place, and/or for 3rd and 4th place, tie-break Speed Routine Battle(s) will be held to determine placings.
- 3.3.3.** Prizes and awards are awarded as follows:
- All Team Members in the events will be awarded medals if placed First, Second or Third.
 - The flags of the countries of the Teams in the events placed First, Second and Third shall be flown and the national anthems of the countries of the Teams placed First shall be played.

4. General rules

- 4.1.** Equipment: Performers are responsible for outfitting themselves in their own suitable clothing and footwear, including flight suits, helmets, goggles, and ear plugs.
- 4.2.** Wind Tunnel Equipage:
- 4.2.1.** The minimum acceptable diameter for the flight chamber is 4,25 metres.
- 4.2.2.** The Sidelines must consist of two (2) vertical lines of lights, which must be changeable in colours. The lights may be LED technology. The Sidelines must extend from the floor up to the top of the transparent walls or 5 metres, whichever is less.
- 4.2.3.** The Rings must have a five (5) cm hole and must be positioned two (2) metres above the cable floor on each Sideline.
- 4.2.4.** The Centreline may be adhesive tape affixed to the transparent tunnel wall and must extend from the floor up to the top of the transparent walls or 5 metres, whichever is less.
- 4.2.5.** The speed setting will be indicated in the tunnel and shall be clearly visible to the Team prior to entering the flight chamber.
- 4.2.6.** The orientation of the two (2) Sidelines with respect to the flight chamber doorway that will be used for entry and exit will be published not less than 90 days before the start of competition.
- 4.2.7.** The wind tunnel equipage must be approved by the Chief Judge prior to the start of the official Training Flights. If any equipment does not meet the requirements as determined by the Chief Judge, this equipment will be deemed to be unusable for the competition.
- 4.2.8.** Video Recording: The Organiser shall record all competition flights in a High Definition 1080 type digital video signal with a minimum of 25 frames per second through a memory card (minimum class 10).
- 4.2.8.1.** For Speed Routines, two cameras must record video, one positioned at one of the Sidelines level with the Ring, and the other positioned at the Centreline.
- 4.2.8.2.** For Free Routines, one camera must record video from a position at the centre of the viewing gallery arc.
- 4.2.9.** The Organiser must provide the Teams with a way of identification of the Team, which will be included in the video along with the numeric ID for the Battle.
- 4.3.** Speed Setting and Training Flights:
- 4.3.1.** Speed Setting: Three (3) minutes per Team will be allocated for speed setting.
- 4.3.2.** Speed Setting and Training Flights may only take place prior to the start of the competition.
- 4.3.3.** Each Team in each event will be given the option of two (2) official Training Flights prior to the competition. The lighted Sidelines plus the judging and scoring systems to be used in the competition will be used for the official Training Flights. For Free Routines, no score will be given.
- 4.3.4.** Before the start of the Training Flights, the team captain has the option to explain the delivered Free Routine description sheet(s). The Teams may present video of previous flights for move explanation.
- 4.4.** The Draw:
- 4.4.1.** The Draw for the Compulsory Patterns will be done publicly and supervised by the Chief Judge. Teams will be given not less than two (2) hours knowledge of the results of the Draw before the competition starts.
- 4.4.2.** The Compulsory Patterns will be drawn as follows: One (1) Pattern from each group (Snakes, Verticals and Mixers), as shown in Addenda A, will be drawn for each Speed Round.
- 4.4.2.1.** All Compulsory Patterns will be singularly placed in three (3) containers, one for each group of Patterns. Individual withdrawal from each container, without replacement, will determine the Patterns to be performed. The routine will begin with the compulsory entrance and end with the compulsory exit sequence.
- 4.4.3.** Freefall: Competitors are not allowed to freefall from any aircraft or use any freefall simulator or wind tunnel, for flights other than competition flights, after the draw has been published.

- 4.5.** Order of Flights: During the Qualifications Rounds, all Teams will fly each round in Team number order. Team numbers will be randomly drawn. During the Tournament, all Battles will fly in the order decided by the highest placing Team in the Qualification Rounds. (The Tournament Brackets, as shown in Addenda E, identify each Battle with a unique numeric ID.)
- 4.5.1.** The FAI Sporting Code, Section 5, Chapter 5.2.5. requirement for the minimum time between flights will not apply for each Team's second flight in the last round of the Tournament and for any tie-break Battles.
- 4.5.2.** The relevant order of flights will be maintained throughout the competition, except for any logistical changes deemed necessary by the Chief Judge and the Meet Director.
- 4.6.** Flight Chamber Entry: Only one (1) doorway leading into the flight chamber will be used for entries and exits. The tunnel will be set to the correct speed decided by the Team during the Speed Setting time. When the tunnel is at the correct speed, a signal will be given to the Team.
- 4.7.** Re-flights:
- 4.7.1.** A re-flight may be granted if the Chief Judge, in agreement with the Meet Director and the FAI Controller, concludes that the performance of a Team has been adversely affected by any external factor(s). The Chief Judge's decision is no grounds for a protest.
- 4.7.2.** Contact or other means of interference between (a) Performer(s) and/or the tunnel walls/cable floor shall not be grounds for a re-flight.
- 4.7.3.** Problems with a competitor's equipment shall not be grounds for a re-flight.
- 4.7.4.** A re-flight will be granted, if a tunnel spotter must abort a Team's flight for any safety reason, provided that there was no intentional act on the part of the Team to create a safety problem.
- 4.7.5.** For safety reasons, if a Performer demonstrates inadequate flying skills and/or persistent unsafe flying requiring repeated intervention by a tunnel spotter, FAI Sporting Code, Section 5, Chapter 4.8 SAFETY will apply.

5. Rules specific to the event

- 5.1.** Teams:
- 5.1.1.** Dynamic Teams may consist of either or both sexes.
- 5.1.2.** A Team may only represent one (1) NAC.
- 5.2.** Routines: The discipline is comprised of Speed Routines and Free Routines.
- 5.2.1.** Teams can optionally deliver a description of their Free Routine(s) to the Chief Judge before the start of the official Training Flights. For this purpose, the Chief Judge should provide a standard form (see Addendum D). Deviation from the Free Routine description will not influence the scoring.
- 5.3.** Number of rounds:
- The Qualification Rounds will have three (3) rounds.
 - The number of rounds in the Tournament is determined by the number of Teams registered.
- 5.4.** Order of the Routines: (F = Free Routine, S = Speed Routine)
- Qualification Rounds: Rd 1 S; Rd 2 S; Rd 3 F.
 - Tournament with 4 Teams: Rd 1 F; Rd 2 F&S.
 - Tournament with 5-8 Teams: Rd 1 F; Rd 2 S; Rd 3 F&S.
 - Tournament with 9-18 Teams: Rd 1 F; Rd 2 S; Rd 3 F; Rd 4 F&S.
 - Tournament with 19-32 Teams: Rd 1 F; Rd 2 S; Rd 3 F; Rd 4 S; Rd 5 F&S.
 - Tournament Tie-Break: S.
- 5.5.** Battles:
- 5.5.1.** For each Battle, the Team who flies first will be decided by the Team who placed higher in the Qualification Rounds.
- 5.5.2.** If a Team does not arrive to the Anti-Chamber in time for their Battle (or is withdrawn or disqualified), the other Team in the Battle will win and may choose whether or not they will fly their routine for that Battle.
- 5.5.3.** If both Teams (neither of which is withdrawn or disqualified) for a specific Battle do not arrive to the Anti-Chamber in time for their Battle, the winner will be the Team who placed higher in the Qualification Rounds.
- 5.6.** Qualification Rounds:
- 5.6.1.** All Teams will fly round 1, then round 2 and then round 3.
- 5.6.2.** Team placings in the Qualification Rounds will be determined as follows:
- Compulsory Round: The final time, after all penalties have been applied, will be used for this calculation. The fastest Team of the round will receive 100 points. All other Teams will be awarded points based on their time compared with the fastest Team. The fastest final time will be divided by the Team's final time and multiplied by 100 to determine their score.

- Free Round: The Team with the highest raw score will receive 100 points. All other Teams will be awarded a proportional fraction of 100 points based on their raw score as a fraction of that earned by the highest Team. Each Team's raw score will be divided by the highest Team's raw score and multiplied by 100 to determine their score.
 - Total scores for the Qualification Rounds are calculated by adding each Team's scores for the three (3) rounds. and then rounded to the first decimal place. For the rounding, intermediate values must be converted from multiple decimal places to one (1), by rounding to the nearest tenth, except where the second decimal digit is exactly halfway between the two values, where it must be rounded to the higher of the two. The maximum possible score is 300.
 - If two (2) or more Teams have equal scores, their placings will be determined by adding their two (2) speed routine times. The Team(s) with the fastest times will earn the higher placing(s).
- 5.6.3.** If one or more Team(s) is(are) withdrawn or disqualified during the Qualification Rounds, the Tournament Bracket (Addenda E) for the number of remaining Teams will be used.
- 5.7.** The Tournament:
- 5.7.1.** Based on their placings from the Qualification Rounds, Teams are put into the appropriate Battles in the Tournament Bracket, as shown in the appropriate Addendum E for the number of Teams in the Event.
- 5.7.1.1.** The maximum number of Teams allowed is thirty-two (32) Teams.
- 5.7.2.** If, after the Tournament has started, any Team(s) is(are) withdrawn or disqualified, they will follow the losing pathways for all their remaining Battles in the Tournament.
- 5.7.3.** The last round of the Tournament determines the final placings of the Teams and will consist of one (1) Free Routine and one (1) Speed Routine.
- 5.7.3.1.** After the completion of the Tournament, for determination of the final placings, any withdrawn and/or disqualified Team(s) will be moved to the lowest placings and then removed.

6. Judging and Scoring

- 6.1.** General: Once any Performer has entered the flight chamber, the flight shall be evaluated and scored.
- 6.2.** Scoring Free Routines:
- 6.2.1.** Criteria for scoring Free Routines:
- Technical Difficulty:
- New original Moves/Patterns are performed.
 - Moves/Patterns performed require precision, e.g., head touching to head with no other grips.
 - Technicality/complexity of Moves/Patterns performed, e.g., complex intermixing and/or embedded moves.
 - Wind loading (tunnel speed setting used).
 - Difficulty of moves and Patterns.
 - See Addendum C.
- Execution:
- Full use of working time.
 - Moves/Patterns are performed without crashing or loss of balance.
 - Use of space in the tunnel.
- Variety:
- A variety of orientations is shown.
 - A variety of Moves/Patterns are performed.
 - Original Moves/Patterns and choreography.
 - A variety of transitions between sequences is shown.
- Flow:
- Display of balance.
 - Uniformity of body position: Efficient, clean positioning for appropriate power from the wind.
 - Synchronisation.
 - Rhythm.
 - Body Form, visually appealing body position(s) are shown.
- Entertainment:
- Use of visual effect(s).

- Choreography; Story telling.
 - Creativity.
 - Excitement/Energy.
- 6.2.2.** For each Free Routine during the Qualification Rounds, each Judge, taking into account the above criteria, will give each Team a score between 0 and 100 points with no decimal point. The five (5) scores will be added and the result divided by five, then rounded to the first decimal place. For the rounding, intermediate values must be converted from multiple decimal places to one (1), by rounding to the nearest tenth, except where the second decimal digit is exactly halfway between the two values, where it must be rounded to the higher of the two.
- 6.2.3.** During the Tournament, at the completion of each Free Routine Battle of two (2) Teams, the Judges, taking into account the above criteria, determine the winning Team of the Battle.
- 6.3.** Scoring Speed Routines: The score is based on the time, measured in thousandths of a second, the Team takes to perform the three (3) Compulsory Patterns, repeated three (3) times as well as the compulsory entrance and exit sequence plus penalty times for infringements and omitted Compulsory Patterns.
- 6.3.1.** Infringements: Each incorrect, incomplete or non judgable Compulsory Pattern or compulsory exit sequence will lead to adding a penalty of five (5) seconds to the total time for the Speed Routine. See the Addenda A for performance and scoring requirements for the Compulsory Patterns and compulsory exit sequence.
- 6.3.2.** The Performers become designated as P#1, P#2, P#3 and P#4 (P#1 and P#2 for D2W) according to the order in which they enter the flight chamber at the start of the Speed Routine.
- 6.3.3.** A five (5) second penalty will apply to a Compulsory Pattern or Exit Sequence if:
- any part of the first Performer's body crosses the doorway entering the flight chamber before the visual signal is given to start the working time.
 - any Performer does not maintain their designated slot. If the same positioning error is carried into the following Patterns to the end of the Speed Routine, this will be considered as one infringement only, provided that the intent of following the performance requirements in the following Patterns and compulsory exit sequence is clearly presented and no other infringement occurs. (After the positioning error, the new order of the Performers must be maintained.)
 - the Team does not stay in view and clearly present the performance requirements to the Judges. E.g., if any Performer flies so high in the Diffuser that the Judges can not determine that the Pattern has been performed correctly, (e.g., properly crossed a Sideline, etc.).
 - the leading Performer completely crosses the next Sideline before the following Performer completely crosses the previous Sideline, i.e., lack of synchronisation. (D2W only)
 - any Performer fails to completely cross a Sideline at the finish of a Pattern before entering the next Pattern. That next Pattern does not receive a time penalty, provided there are no other infringements.
- 6.3.4.** Each Compulsory Pattern can receive a maximum of only one (1) five (5) second time penalty.
- 6.3.5.** An omitted Compulsory Pattern will lead to adding a penalty of twenty (20) seconds to the total time for the Speed Routine. An omission is one of the following:
- A Compulsory Pattern is missing from the drawn sequence.
 - No clear intent to finish the Compulsory Pattern (e.g., after an infringement) and there is a resulting time advantage to the Team.
 - No clear intent to perform the correct Compulsory Pattern is seen and another Pattern is presented and there is a time advantage to the Team resulting from the substitution.
- 6.3.5.1.** If a Team crashes or becomes disorganised during a Compulsory Pattern, the Team may continue to the next Compulsory Pattern accruing only a five (5) time penalty provided that the Judges see the Team losing time in the process of getting organised and there is no time advantage to the Team.
- 6.3.6.** One or more Judges may make an evaluation of any infringements and of an omission.
- 6.3.7.** During the Tournament, the Team with the fastest time, after all time penalties are applied, wins the Battle.
- 6.3.8.** A Team may challenge an infringement or omission given by the Judges.
- 6.3.8.1.** During the Qualification Rounds, the Team must make their challenge before the start of the next round.
- 6.3.8.2.** During the Tournament, the Team must make their challenge before the start of the next Battle.

- 6.3.8.3.** The Judges will watch the video of the flight and determine whether or not the infringement or omission occurred.
- 6.3.8.4.** If the Judges determine that the infringement or omission occurred, the Team may not again challenge another infringement or omission given by the Judges.
- 6.4.** Scores and Results:
- 6.4.1.** The final time for each Speed Routine will be published, including the raw speed routine completion time, time penalties, infringement types and any omissions.
- 6.4.2.** For each Free Routine during the Qualification Rounds (para 5.6.), the score for each judge will be published.
- 6.4.3.** For each Free Routine during the Tournament (para 5.7.), the decision for each judge will be published.
- 6.4.4.** Final team placings will be determined by a series of Battles in the Tournament (para 5.7.).
- 6.4.5.** For all Teams, the individual Battles with their winners will be published on the Tournament Bracket diagram.
- 6.5.** Judging rules:
- 6.5.1.** Viewing the Flights:
- 6.5.1.1.** The Judges will watch each Team's flight from the flight chamber viewing gallery.
- 6.5.1.2.** For the Free Routines in the Qualification Rounds, the Judges may review video of any or all of the Teams.
- 6.5.2.** Speed Routine Judging:
- 6.5.2.1.** A panel of five (5) Judges must evaluate each Team's Speed Routine.
- 6.5.2.2.** Two (2) Judges, one positioned at each Sideline, will evaluate for complete crossings of the Sidelines. In D2W, they will also evaluate Synchronisation. Each Sideline Judge must be positioned such that the Sideline on the far wall is obscured from view by the Sideline on the near wall. One Sideline Judge will also be the Timing Judge and will operate a chronometer, which will start the working time. The chronometer will be stopped at the end of working time (para 2.14.1.)
- 6.5.2.3.** A Ring Judge will evaluate that no part of any Performer's body is visible in the Ring (Vertical Patterns only). The Ring Judge must be positioned two (2) metres from the Ring with the Judge's eye level with the Ring with the outline of the far Ring visible through the five (5) cm hole of the near Ring.
- 6.5.2.4.** A Judge, positioned at the Centreline, will evaluate the Team's correctness in following the performance description of each Compulsory Pattern (e.g., Performers flying in the correct order, pirouettes in correct direction, etc.) In D2W, this judge will also evaluate for complete crossings of the Centreline.
- 6.5.2.5.** A Judge, positioned between the Centreline and a Sideline Judge, will evaluate the Team's correctness in following the performance description of each Compulsory Pattern (e.g., Performers flying in the correct order, pirouettes in correct direction, etc.)
- 6.5.2.6.** The Judges may utilise video monitors and these cameras must record video (para 4.2.8.) The cameras for the video monitors must be positioned in compliance with the above judging positions. The Sideline camera must show the entire height of the glass wall or five (5) metres, whichever is less.
- 6.5.3.** Free Routine Judging:
- 6.5.3.1.** A panel of five (5) Judges must evaluate each Team's Free Routine, each Judge will evaluate all criteria (para 6.2.).
- 6.5.3.2.** The Free Routine Judges will be positioned in an arc spread throughout the entire viewing gallery, not including the Anti-Chamber and controller booth. The Event Judge will sit at the centre of the Judges.
- 6.5.3.3.** The chronometer will be operated by the Judges or by (a) person(s) appointed by the Chief Judge or by laser technology, and will be started at the beginning of working time (para 2.14.2.).
- 6.5.4.** At the end of working time, a signal will be given and, for the Free Routine, the Judges will look away from the flight chamber. Without discussion with other Judges, each Judge will record their evaluation and submit it to the Event Judge.
- 6.5.4.1.** In consideration of the five (5) criteria (para 6.2.), each Judge will select the best Team in the Battle.
- 6.5.5.** The Judges may use an electronic scoring system to record their evaluations.

7. Rules specific to the competition

- 7.1.** Composition of Delegations: Each Delegation may be comprised of:
- One (1) Head of Delegation

- One (1) Team Manager
 - A maximum of two (2) D2W Teams and two (2) D4W Teams for a WISC or Continental Indoor Skydiving Championship.
 - The number of Teams for an Indoor Skydiving World Cup will be up to the organiser.
- 7.2.** Competition schedule: The competition will be organised in accordance with one (1) official training day and a minimum time frame of three (3) competition days.

ADDENDA A1, A2, A3, B, C, D, E

- Addendum A1: Speed Routine Compulsory Patterns - Snakes
- Addendum A2: Speed Routine Compulsory Patterns - Verticals
- Addendum A3: Speed Routine Compulsory Patterns - Mixers
- Addendum B: Basic Orientations, Rotations and Pathways
- Addendum C: Difficulty
- Addendum D: Free Routine Description Form
- Addenda E: Tournament Brackets

ADDENDUM – A1

SPEED ROUTINE COMPULSORY PATTERNS - SNAKES PERFORMANCE REQUIREMENTS & JUDGEMENT CRITERIA

- The following Performer(s) follow the leader throughout the illustrated pathway, with respect to top view. If the Performers change their order of following one another or a different Performer becomes the leader during any Snake, a five (5) second penalty applies.

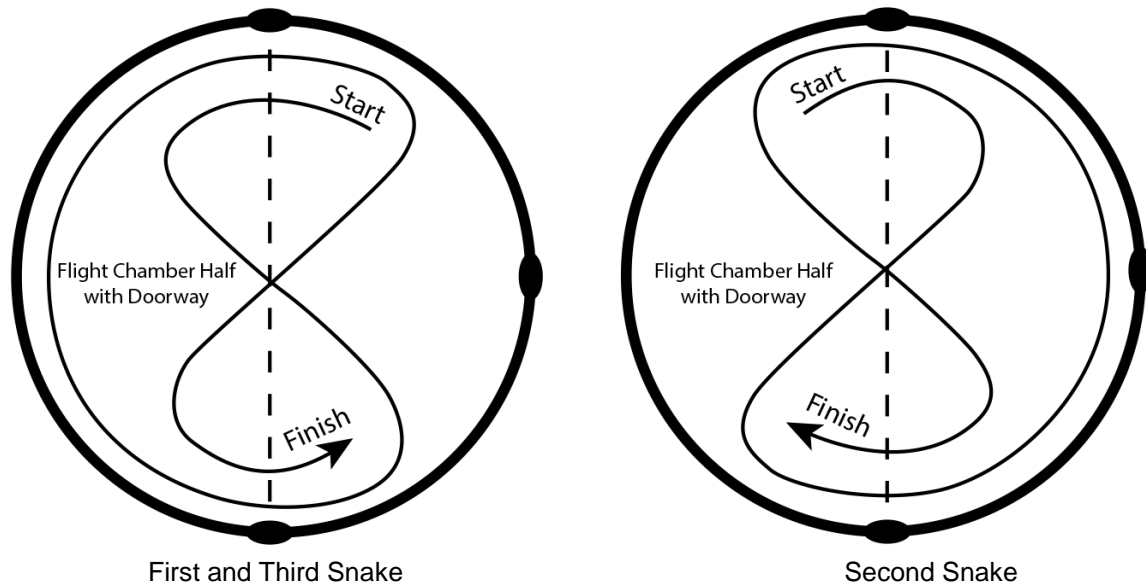

- If any Performer flies any Snake differently than described, (e.g., failure to switch to outface during a Switching Snake, etc.) a five (5) second penalty applies.
- If the Compulsory Entrance is not performed correctly, a five (5) second penalty will apply to the first Snake.
- The Sidelines and Centreline apply.
- Each Performer must be in the orientation of the Snake before crossing the start Sideline after the Compulsory Entrance. If any Performer's body is not in the correct orientation, (e.g., it is horizontal,) before crossing the start Sideline, a five (5) second penalty applies.
- Each Performer's entire body must completely cross each Sideline and Centreline. If a Sideline or Centreline is not completely crossed, (e.g., a hand does not pass the line, even though the rest of the body does,) a five (5) second penalty applies.
- During any Snake, each Performer crosses a Sideline six (6) times.

Compulsory Entrance (D4W & D2W)

P#1, followed by P#2 through P#4, must completely cross the vertical plane comprised by the Sidelines. The Performers may cross this vertical plane in any orientation. Maintaining sequential order, the Performers must flow counterclockwise (with respect to the top view) into the first Snake.

S-1 Head-down Inface Snake (D4W & D2W)

Performers remain in head-down inface carving during the entire Pattern. Performers begin by carving towards the Performers' left in the first and third Snake (right in the second Snake). When passing through the centre the first time, each Performer changes to carving towards his/her right in the first and third Snake (left in the second Snake). When passing through the centre the second time, each Performer changes to carving towards his/her left in the first and third Snake (right in the second Snake).

S-2 Head-down Switching Snake (D4W & D2W)

Performers remain head-down during the entire Pattern. Performers begin by inface carving towards the Performers' left in the first and third Snake (right in the second Snake). When passing through the centre the first time, each Performer changes to outface carving towards his/her left in the first and third Snake

(right in the second Snake). When passing through the centre the second time, each Performer returns to inface carving towards his/her left in the first and third Snake (right in the second Snake).

S-3 Head-up Inface Snake (D4W & D2W)

Performers remain in head-up inface carving during the entire Pattern. Performers begin by carving towards the Performers' right in the first and third Snake (left in the second Snake). When passing through the centre the first time, each Performer changes to carving towards his/her left in the first and third Snake (right in the second Snake). When passing through the centre the second time, each Performer changes to carving towards his/her right in the first and third Snake (left in the second Snake).

S-4 Head-up Switching Snake (D4W & D2W)

Performers remain head-up during the entire Pattern. Performers begin by inface carving towards the Performers' right in the first and third Snake (left in the second Snake). When passing through the centre the first time, each Performer changes to outface carving towards his/her right in the first and third Snake (left in the second Snake). When passing through the centre the second time, each Performer returns to inface carving towards his/her right in the first and third Snake (left in the second Snake).

S-5 Head-down Mixed Snake (D4W & D2W)

Performers begin by head-down inface carving towards the Performers' left in the first and third Snake (right in the second Snake). When passing through the centre the first time, each Performer transitions through the back down orientation to head-up inface carving towards his/her left in the first and third Snake (right in the second Snake). When passing through the centre the second time, each Performer transitions through the back-down orientation to head-down inface carving towards his/her left in the first and third Snake (right in the second Snake).

S-6 Head-up Mixed Snake (D4W & D2W)

Performers begin by head-up inface carving towards the Performers' right in the first and third Snake (left in the second Snake). When passing through the centre the first time, each Performer transitions through the back down orientation to head-down inface carving towards his/her right in the first and third Snake (left in the second Snake). When passing through the centre the second time, each Performer transitions through the back-down orientation to head-up inface carving towards his/her right in the first and third Snake (left in the second Snake).

ADDENDUM – A2

SPEED ROUTINE COMPULSORY PATTERNS - VERTICALS PERFORMANCE REQUIREMENTS & JUDGEMENT CRITERIA

- If the Compulsory Transition to the Vertical from the Snake is not performed correctly, a five (5) second penalty will apply to the Vertical.
- At the beginning and the end of the Vertical, if each Performer is not on their side of the Centreline, a five (5) second penalty applies.
- If any Performer flies any Vertical Pattern differently than described, (e.g., Performers not pirouetting in the same direction during a Classic, etc.) a five (5) second penalty applies.
- The Sidelines and Ring apply.
- Teams must fly around the Ring. The pairs of Performers must completely cross a Sideline on each half of the Vertical. If a Sideline is not completely crossed, a five (5) second penalty applies.
- No part of any Performer's body may be visible through the Ring. If any part of a Performer's body is visible through the Ring, a five (5) second penalty applies.
- The Centreline applies for V-2, Butterfly. If each Performer does not completely cross the Centreline, when flying over the Ring, a five (5) second penalty applies.
- In each Vertical (not including the Compulsory Transition), each Performer will cross a Sideline four (4) times.

D4W VERTICALS

Compulsory Transition from Any Head-Down Snake to Any Vertical

While head-down, P#1, followed by P#2 through P#4, must cross the Centreline and the start Sideline before starting any Vertical. P#1 and P#3 must continue across the Centreline again before starting any Vertical.

Compulsory Transition from Any Head-Up Snake to Any Vertical

While head-up, P#1 and P#3 must cross the Centreline. When crossing through the Sidelines, each Performer transitions to head-down in a half inface Reverse Eagle before starting any Vertical.

V-1 Back Layout (D4W)

While head-down, the Performers separate into two (2) pairs. P#1 & P#2 will be the leading pair and P#3 & P#4 will be the following pair. Each pair, one after the other, flies forward over the Ring and then performs one half outface Eagle passing under the Ring to head-up. Next, each pair, one after the other, flies backward over the Ring and performs one half inface Reverse Eagle under the Ring to head-down.

V-2 Butterfly with Bottom Loops (D4W)

While head-down, the Performers separate into two (2) pairs. P#1 & P#2 will be the leading pair and P#3 & P#4 will be the following pair. Each pair, one after the other, flies forward, with the two (2) Performers in the pair crossing each other, over the Ring. Then, each pair, one after the other, performs one half outface Eagle with one half back loop passing under the Ring to head-down. When initiating the half back loop each Performer must be on their side of the Centreline. This sequence is performed twice.

V-3 Classic (D4W)

While head-down, the Performers separate into two (2) pairs. P#1 & P#2 will be the leading pair and P#3 & P#4 will be the following pair. While head-down and flying over the Ring, each Performer in the pair performs a 180° pirouette in the same direction. The 180° pirouette must rotate away from the start Sideline and be performed before the head is below the ring. Each pair then performs one half inface Eagle under the Ring to head-up. While head-up and flying over the Ring, each Performer in the pair performs a 180° pirouette in the same direction. And the pair performs one half inface Reverse Eagle under the Ring to head-down.

V-4 Half Barrel Roll 180° (D4W)

While head-down, the Performers separate into two (2) pairs. P#1 & P#2 will be the leading pair and P#3 & P#4 will be the following pair. Each pair, one after the other, flies forward over the Ring and then

performs one half outface Eagle with one half barrel roll in the same direction passing under the Ring to head-up. The half barrel roll must rotate away from the start Sideline and be initiated when the torso is between the sidelines. As they fly over the Ring, they perform a 180° pirouette in the same direction. Each pair, one after the other, then, performs one half inface Reverse Eagle under the Ring to head-down.

V-5 Head-Down 360° (D4W)

While head-down, the Performers separate into two (2) pairs. P#1 & P#2 will be the leading pair and P#3 & P#4 will be the following pair. Each pair, one after the other, flies forward over the Ring and then performs one half outface Eagle with one half back loop passing under the Ring to head-down. As they fly over the Ring, they perform a 360° pirouette in the same direction and perform one half outface Eagle with one half back loop passing under the Ring to head-down. The 360° pirouette must rotate away from the start Sideline.

V-6 Head-Up 360° (D4W)

While head-down, the Performers separate into two (2) pairs. P#1 & P#2 will be the leading pair and P#3 & P#4 will be the following pair. Each pair, one after the other, flies forward over the Ring and then performs one half outface Eagle passing under the Ring to head-up. Next, each pair flies backwards over the Ring and performs a 360° pirouette in the same direction and performs one half inface Reverse Eagle under the Ring to head-down. The 360° pirouette must rotate away from the start Sideline.

D2W VERTICALS

Compulsory Transition from Any Head-Down Snake to Any Vertical

While head-down, P#1, followed by P#2, must cross the Centreline and the start Sideline before starting any Vertical. P#1 must continue across the Centreline again before starting any Vertical.

Compulsory Transition from Any Head-Up Snake to Any Vertical

While head-up, P#1 must cross the Centreline. When crossing a Sideline, each Performer transitions to head-down in a half inface Reverse Eagle before starting any Vertical.

V-1 Back Layout (D2W)

While head-down, the two (2) Performers fly this Pattern as a pair. The pair flies forward over the Ring and then performs one half outface Eagle passing under the Ring to head-up. Next, the pair flies backward over the Ring and performs one half inface Reverse Eagle under the Ring to head-down.

V-2 Butterfly with Bottom Loops (D2W)

While head-down, the two (2) Performers fly this Pattern as a pair. The pair flies forward, with the two (2) Performers in the pair crossing each other, over the Ring. The pair, then, performs one half outface Eagle with one half back loop passing under the Ring to head-down. When initiating the half back loop each Performer must be on their side of the Centreline. This sequence is performed twice.

V-3 Classic (D2W)

While head-down, the two (2) Performers fly this Pattern as a pair. While head-down and flying over the Ring, each Performer in the pair performs a 180° pirouette in the same direction. The 180° pirouette must rotate away from the start Sideline and be performed before the head is below the ring. The pair, then, performs one half inface Eagle under the Ring to head-up. While head-up and flying over the Ring, each Performer in the pair performs a 180° pirouette in the same direction. And the pair performs one half inface Reverse Eagle under the Ring to head-down.

V-4 Half Barrel Roll 180° (D2W)

While head-down, the two (2) Performers fly this Pattern as a pair. The pair flies forward over the Ring and then performs one half outface Eagle with one half barrel roll in the same direction passing under the Ring to head-up. The half barrel roll must rotate away from the start Sideline and be initiated when the torso is between the sidelines. As they fly over the Ring, they perform a 180° pirouette in the same direction. The pair, then, performs one half inface Reverse Eagle under the Ring to head-down.

V-5 Head-Down 360° (D2W)

While head-down, the two (2) Performers fly this Pattern as a pair. The pair flies forward over the ring and then performs one half outface Eagle with one half back loop passing under the Ring to head-down. As they fly over the Ring, they perform a 360° pirouette in the same direction and perform one half outface Eagle with one half back loop passing under the Ring to head-down. The 360° pirouette must rotate away from the start Sideline.

V-6 Head-Up 360° (D2W)

While head-down, the two (2) Performers fly this Pattern as a pair. The pair flies forward over the Ring and then performs one half outface Eagle passing under the Ring to head-up. Next, the pair flies backward over the Ring and performs 360° pirouette in the same direction and perform one half inface Reverse Eagle under the Ring to head-down. The 360° pirouette must rotate away from the start Sideline.

ADDENDUM – A3

SPEED ROUTINE COMPULSORY PATTERNS - MIXERS PERFORMANCE REQUIREMENTS & JUDGEMENT CRITERIA

- If any Performer flies any Mixer differently than described, (e.g., failure to switch to outface during a Shuffler, etc.) a five (5) second penalty applies.
- If the transition from the Mixer to the appropriate Snake is not performed correctly, a five (5) second penalty will apply to the Mixer.
- At the beginning and the end of the Mixer, if each Performer is not on their side of the Centreline, a five (5) second penalty applies.
- If any Performer crosses through the centre in the incorrect order during any Shuffler, (e.g., P#2 crosses the centre before P#1,) a five (5) second penalty applies.
- The Sidelines apply.
- Each Performer's entire body must completely cross a Sideline during each part of a Mixer. If a Sideline is not completely crossed, (e.g., a Performer does not perform their circle sufficiently wide for their entire body to completely cross a Sideline on each half circle,) a five (5) second penalty applies.
- The Centreline also applies during any Shuffler.
- When starting any Circle, as each pair separates into carving in opposite directions, each Performer of the pair must be on their respective side of the Centreline.

D4W MIXERS

M-1 Head-Down Inface Circles (D4W)

While head-down, each pair of Performers separates into inface carving in opposite directions, with P#1 followed by P#3, crossing a Sideline, and P#2 followed by P#4, crossing the other Sideline. While head-down, P#1 & P#3, facing one another, and P#2 & P#4, facing one another, perform an additional 360° of inface carving, crossing a Sideline two (2) additional times, once for each half circle. Then, P#1 & P#2 become the leading pair and fly forward, crossing through the Sidelines, followed by P#3 & P#4. Thence...

M-2 Head-Up Inface Circles (D4W)

While head-down, each pair flies forward, crossing through the Sidelines, and performs one half back loop to head-up. While head-up, each pair of Performers separates into inface carving in opposite directions, with P#1 followed by P#3, crossing a Sideline and P#2 followed by P#4, crossing the other Sideline. A five (5) penalty will apply if any Performer is not head-up before reaching the Sideline. While head-up, P#1 & P#3, facing one another, and P#2 & P#4, facing one another, perform an additional 360° of inface carving, crossing a Sideline two (2) additional times, once for each half circle. P#1 & P#2 become the leading pair and perform one half inface Reverse Eagle, crossing through the Sidelines, to head-down, followed by P#3 & P#4. And P#1 & P#2 fly forward, crossing through the Sidelines, followed by P#3 & P#4. Thence...

M-3 Mixed Circles (D4W)

While head-down, each pair flies directly through the Sidelines, presenting their backs to each other into 180° of inface carving in opposite directions, with P#1 followed by P#3, crossing a Sideline and P#2 followed by P#4, crossing the other Sideline. Each pair, one after the other, flies forward, crossing through the Sidelines, and then performs one half outface Eagle, passing through the Sidelines again, to head-up, into 180° of outface carving in opposite directions, with P#1 followed by P#3, crossing a Sideline and P#2 followed by P#4, crossing the other Sideline. Then, P#1 & P#2 become the leading pair and fly backward, crossing through the Sidelines, followed by P#3 & P#4. Each pair, one after the other, then performs one half inface Reverse Eagle, crossing through the Sidelines, to head-down. And P#1 & P#2 fly forward, crossing through the Sidelines, followed by P#3 & P#4. Thence...

M-4 Reverse Mixed Circles (D4W)

While head-down, each pair flies forward, crossing through the Sidelines, and then performs one half outface Eagle, crossing through the Sidelines, into 180° of head-up outface carving in opposite directions, with P#1 followed by P#3, crossing a Sideline and P#2 followed by P#4, crossing the other Sideline.

Then, while head-up, P#1 & P#2 become the leading pair and fly backward, crossing through the Sidelines, followed by P#3 & P#4. Each pair, one after the other, then performs one half inface Reverse Eagle, crossing through the Sidelines, to head-down. Then, each pair flies directly through the Sidelines, presenting their backs to each other into 180° of inface carving in opposite directions, with P#1 followed by P#3, crossing a Sideline and P#2 followed by P#4, crossing the other Sideline. Then, P#1 & P#2 become the leading pair and fly forward through the Sidelines, followed by P#3 & P#4. Thence...

M-5 Head-down Shuffler (D4W)

While head-down, each pair of Performers separates into inface carving in opposite directions, with P#1 followed by P#3, crossing a Sideline and P#2 followed by P#4, crossing the other Sideline. Next, P#1, then P#2, then P#3 and then P#4, pass through the centre into 180° of outface carving, with P#1, then P#3, crossing a Sideline and P#2, then P#4, crossing the other Sideline. Continuing the Shuffler, P#1, then P#2, then P#3 and then P#4, pass through the centre into 180° of inface carving, with P#1, then P#3, crossing a Sideline and P#2, then P#4, crossing the other Sideline. Then, P#1 & P#2 become the leading pair and fly forward through the Sidelines, followed by P#3 & P#4. Thence...

M-6 Head-up Shuffler (D4W)

While head-down, each pair flies forward, crossing through the Sidelines, and performs one half back loop to head-up. While head-up, each pair of Performers separates into inface carving in opposite directions, with P#1 followed by P#3, crossing a Sideline and P#2 followed by P#4, crossing the other Sideline. A five (5) penalty will apply if any Performer is not head-up before reaching the Sideline. Next, P#1, then P#2, then P#3 and then P#4, pass through the centre into 180° of outface carving, with P#1, then P#3, crossing a Sideline and P#2, then P#4, crossing the other Sideline. Continuing the Shuffler, P#1, then P#2, then P#3 and then P#4, pass through the centre into 180° of inface carving, with P#1, then P#3, crossing a Sideline and P#2, then P#4, crossing the other Sideline. Then, P#1 & P#2 become the leading pair and perform one half inface Reverse Eagle, crossing through the Sidelines, to head-down, followed by P#3 & P#4. Each pair, then, flies forward, crossing through the Sidelines. Thence...

M-7 Mixed Shuffler (D4W)

While head-down, each pair of Performers separates into inface carving in opposite directions, with P#1 followed by P#3, crossing a Sideline and P#2 followed by P#4, crossing the other Sideline. Next, P#1, then P#2, then P#3 and then P#4, pass through the centre, while performing one half inface Eagle to head-up and then perform 180° of inface carving, with P#1, then P#3, crossing a Sideline and P#2, then P#4, crossing the other Sideline. Continuing the Shuffler, while head-up, P#1, then P#2, then P#3 and then P#4, pass through the centre and perform 180° of outface carving, with P#1, then P#3, crossing a Sideline and P#2, then P#4, crossing the other Sideline. Then, P#1 & P#2 become the leading pair and fly backward through the Sidelines, followed by P#3 & P#4. Each pair, one after the other, then performs one half inface Reverse Eagle, crossing through the Sidelines, to head-down. And P#1 & P#2 fly forward, crossing through the Sidelines, followed by P#3 & P#4. Thence...

...To transition to a head-down Snake (D4W): Each pair, one after the other, then performs one half outface Eagle with one half back loop, crossing through the Sidelines, to head-down. They, then, inface carve, crossing a Sideline, before starting any Head-down Snake or Head-down Compulsory Exit.

...To transition to a head-up Snake (D4W): Each pair, one after the other, then performs one half outface Eagle, crossing through the Sidelines, to head-up, ending with each Performer completely on their side of the Centreline. Then, while headup, each pair flies backward through the Sidelines, before starting any Head-up Snake or Head-up Compulsory Exit.

Head-down Compulsory Exit Sequence (D4W)

While head-down, P#1, followed by P#2 through P#4, will inface carve towards the Performers' right, completely crossing the Centreline and the start Sideline before exiting the flight chamber from the far side.

Head-up Compulsory Exit Sequence (D4W)

While head-up, P#1, followed by P#2 through P#4, will inface carve towards the Performers' left, completely crossing one Sideline and the Centreline once before exiting the flight chamber from the far side.

D2W MIXERS

M-1 Head-down Inface Circles (D2W)

While head-down, the two (2) Performers separate into inface carving in opposite directions, with P#1 crossing a Sideline and P#2 crossing the other Sideline. While head-down, they perform 360° of inface carving, crossing a Sideline two (2) additional times, once for each half circle. Joining as a pair, the Performers then fly forward, crossing through the Sidelines. Thence...

M-2 Head-Up Inface Circles (D2W)

While head-down, the two (2) Performers, as a pair, fly forward, crossing through the Sidelines, and perform one half back loop to head-up. While head-up, the two (2) Performers separate into inface carving in opposite directions, with P#1 crossing a Sideline and P#2 crossing the other Sideline. A five (5) penalty will apply if any Performer is not head-up before reaching the Sideline. While head-up, they perform an additional 360° of inface carving, crossing a Sideline two (2) additional times, once for each half circle. Joining as a pair, the Performers perform one half inface Reverse Eagle, crossing through the Sidelines, to head-down and then fly forward, crossing through the Sidelines. Thence...

M-3 Mixed Circles (D2W)

While head-down, the two (2) Performers, as a pair, fly directly through the Sidelines, presenting their backs to each other into 180° of inface carving in opposite directions, with P#1 crossing a Sideline and P#2 crossing the other Sideline. As a pair, the Performers fly forward, crossing through the Sidelines, and then performs one half outface Eagle, passing through the Sidelines again, to head-up, into 180° of outface carving in opposite directions, with P#1 crossing a Sideline and P#2 crossing the other Sideline. Joining as a pair, the Performers fly backward, crossing through the Sidelines. The pair, then performs one half inface Reverse Eagle, crossing through the Sidelines, to head-down. And the pair flies forward, crossing through the Sidelines. Thence...

M-4 Reverse Mixed Circles (D2W)

While head-down, the pair flies forward, crossing through the Sidelines, and then performs one half outface Eagle, crossing through the Sidelines, into 180° of head-up outface carving in opposite directions, with P#1 crossing a Sideline and P#2 crossing the other Sideline. While head-up, both Performers, as a pair, fly backward, crossing through the Sidelines, and then perform one half inface Reverse Eagle, crossing through the Sidelines again, to head-down. The pair then flies directly through the Sidelines, presenting their backs to each other into 180° of inface carving in opposite directions, with P#1 crossing a Sideline and P#2 crossing the other Sideline. Joining as a pair, the Performers fly forward, crossing through the Sidelines. Thence...

M-5 Head-down Shuffler (D2W)

While head-down, the two (2) Performers separate into inface carving in opposite directions, with P#1 crossing a Sideline and P#2 crossing the other Sideline. Next, P#1, then P#2, passes through the centre (completely crossing the Centreline) into 180° of outface carving, with P#1 crossing a Sideline and P#2 crossing the other Sideline. Continuing the Shuffler, P#1, then P#2, passes through the centre (completely crossing the Centreline) into 180° of inface carving, with P#1 crossing a Sideline and P#2 crossing the other Sideline. Joining as a pair, the Performers fly forward through the Sidelines. Thence...

M-6 Head-up Shuffler (D2W)

While head-down, the two (2) Performers, as a pair, fly forward, crossing through the Sidelines, and perform one half back loop to head-up. While head-up, the two (2) Performers separate into inface carving in opposite directions, with P#1 crossing a Sideline and P#2 crossing the other Sideline. A five (5) penalty will apply if any Performer is not head-up before reaching the Sideline. Next, P#1, then P#2, passes through the centre (completely crossing the Centreline) into 180° of outface carving, with P#1 crossing a Sideline and P#2 crossing the other Sideline. Continuing the Shuffler, P#1, then P#2, passes through the centre (completely crossing the Centreline) into 180° of inface carving, with P#1 crossing a Sideline and P#2 crossing the other Sideline. Joining as a pair, the Performers perform one half inface Reverse Eagle, crossing through the Sidelines, to head-down. The Performers then fly forward, crossing through the Sidelines. Thence...

M-7 Mixed Shuffler (D2W)

While head-down, the two (2) Performers separate into inface carving in opposite directions, with P#1, crossing a Sideline and P#2, crossing the other Sideline. Next, P#1 then P#2, pass through the centre, while performing one half inface Eagle to head-up and then perform 180° of inface carving, with P#1 crossing a Sideline and P#2 crossing the other Sideline. Continuing the Shuffler, while head-up, P#1, then P#2, pass through the centre and then perform 180° of outface carving, with P#1, crossing a Sideline and P#2 crossing the other Sideline. Joining as a pair, the Performers fly backward through the Sidelines. The Performers, then, perform one half inface Reverse Eagle, crossing through the Sidelines, to head-down and then fly forward, crossing through the Sidelines. Thence...

...To transition to a head-down Snake or Exit Sequence (D2W): The pair, then, performs one half outface Eagle with one half back loop, crossing through the Sidelines, to head-down. The Performers, then, inface carve, crossing a Sideline, before starting any Head-down Snake or Head-down Compulsory Exit.

...To transition to a head-up Snake or Exit Sequence (D2W): The pair, then, performs one half outface Eagle, crossing through the Sidelines, to head-up, ending with each Performer completely on their side of the Centreline. Then, while head-up, the pair flies backward through the Sidelines, before starting any Head-up Snake or Head-up Compulsory Exit.

Head-down Compulsory Exit Sequence (D2W)

While head-down, P#1, followed by P#2, will inface carve towards the Performers' right, completely crossing the Centreline and the start Sideline before exiting the flight chamber from the far side.

Head-up Compulsory Exit Sequence (D2W)

While head-up, P#1, followed by P#2, will inface carve towards the Performers' left, completely crossing one Sideline and the Centreline once before exiting the flight chamber from the far side.

ADDENDUM B BASIC ORIENTATIONS, ROTATIONS AND PATHWAYS

A. ORIENTATIONS

There are six (6) basic orientations (not including diagonal orientations) which a body can have to the wind (or cable floor). These define which way the torso is oriented.

A-1. Belly-down Orientation

The torso is horizontal, on its front, facing down towards the wind (or the cable floor).

A-2. Back-down Orientation

The torso is horizontal, on its back, facing up, away from the wind (towards the ceiling).

A-3. Sideways Orientation

The torso is horizontal, on its side, with either side facing towards the wind (or cable floor). The chest is facing the tunnel wall.

A-4. Head-up Orientation (HU)

The torso is vertical with the head up, directly away from the wind (towards the ceiling). For the Compulsory Patterns, the Performers may lean, but the feet must be below the knees, the knees below the hips and the hips below the shoulders.

A-5. Head-down Orientation (HD)

The torso is vertical with the head down, pointing directly down into the wind (towards the cable floor). For the Compulsory Patterns, the Performers may lean, but the shoulders must be below the hips, the hips below the knees and the knees below the feet.

B. ROTATION AXES

Most moves involve a form of rotational motion of the body. A total of five (5) axes are used to describe the six (6) possible basic rotational motions.

B-1. Wind Axes

There are two inertial axes which stay fixed with respect to the wind (or cable floor).

Vertical Axis

The vertical axis remains parallel to the wind, (pointing from the ceiling to the cable floor). Spins are rotations about the Vertical Axis.

Horizontal Axis

The horizontal axis is any axis perpendicular (90°) to the wind, (pointing to the tunnel wall). It may have any heading (pointing towards any wall).

B-2. Body Axes

There are three (3) body axes which stay fixed with respect to each Performer's body.

Body Head-Tail Axis

The body head-tail axis is oriented lengthwise, pointing from head to tail-bone, normally through the Performer's torso. (In a layout position, the head and feet are in the same line. When the body is bent at the hips, this axis is aligned with the spine and does not include the legs.)

Body Front-Back Axis

The body front-back axis is oriented forwards and backwards, pointing from front to back, normally through the Performer's belly.

Body Left-Right Axis

The body left-right axis is oriented sideways, pointing from left to right, normally through the Performer's hips.

C. BASIC ROTATIONAL ACTIONS

There are six (6) basic rotational actions. Twisting combines rotational actions by adding a rotation about the body head-tail axis during a rotation about the body left-right or front-back axis.

C-1. Flat Turns

Flat turns involve a rotation about the body front-back axis when that axis is aligned with the vertical axis. The Performer's heading is changing. The body can be belly-down or back-down while performing a flat turn.

C-2 Pirouettes

Pirouettes involve a rotation about the body head-tail axis when that axis is aligned with the vertical axis. The Performer's heading is changing. The body can be head-up or head-down while performing a pirouette.

C-3 Barrel Rolls

A barrel roll is a rotation about the body head-tail axis when that axis is aligned with the horizontal axis. A barrel roll may begin and end in a belly-down, back-down or sideways orientation.

C-4 Cartwheels

A cartwheel is a head-over-heels rotation about the body front-back axis when that axis is aligned with the horizontal axis. The body passes through a head-up, sideways and/or head-down orientations during the course of a cartwheel. A cartwheel needs not start nor finish in an exact head-up, sideways or head-down orientation. A cartwheel is considered to be a full cartwheel when the head has travelled 360° around the horizontal axis from the point at which it started. A cartwheel may be performed to the right or left.

C-5. Loops

A loop is a head-over-heels rotation about the body left-right axis when that axis is aligned with the horizontal axis. The body passes through a head-up, belly-down, head-down and/or back-down orientation during the course of the loop. A loop may begin and end in a head-up, belly-down, head-down and/or back-down orientation. A loop needs not start nor finish in an exact head-up, belly-down, head-down and/or back-down orientation. A loop is considered to be a full loop when the head has travelled 360° around the horizontal axis from the point at which is started. There are two (2) kinds of loops. (Loops are referred to by the direction in which the loop is initiated, since in the case of twisting loops, the direction in which the loop completes may be different from the direction at the start.)

Back Loop

A back loop is a loop rotation initiated with the torso rotating backwards.

Front Loop

A front loop is a loop rotation initiated with the torso rotating forwards.

C-6. Side Loops (Loops on the Side)

A loop in the sideways orientation is a rotation about the body left-right axis when that axis is aligned with the vertical axis. For example, a Spinning Egg is a true loop on the side.

C-7. Twists

Twisting combines rotational actions by adding a rotation about the body head-tail axis during a rotation about the body left-right or front-back axis, aligned with either the horizontal or vertical axis. There are two (2) basic categories of twists.

Vertical Twists

A vertical twist is a head-over-heels rotation about the horizontal axis (loop or cartwheel) combined with a rotation about the body head-tail axis. A single or full twist is defined to be a 360° rotation about the body head-tail axis over the course of a 360° loop or cartwheel. The amount of twist contained within a loop or cartwheel is the amount of twisting rotation completed after a 360° looping or cartwheeling rotation has been performed, when measured from the point in the loop or cartwheel at which the twist was first initiated. Twists may be initiated at any position in the loop or cartwheel and in any direction.

Horizontal Twists

A horizontal twist is a rotation about the vertical axis (flat turn or side loop) combined with a rotation about the body head-tail axis. A single or full twist is defined to be a 360° rotation about the body head-tail axis over the course of a 360° flat turn or side loop. For example, a Flip Through is a horizontal twist.

D. CIRCULAR PATHWAYS

There are two (2) basic types of circular pathways a Performer may follow, which can be performed either infacing or outfacing. Circular pathways may have embedded moves (e.g. Bottom Loop) or intermixing of Performers.

Infacing

The front of the torso faces inward towards the concave side of the pathway, usually, but not always, towards the centre of the flight chamber.

Outfacing

The front of the torso faces outward, away from the concave side of the pathway, usually, but not always, towards the wall of the flight chamber.

D-1. Carving

The Performer(s) body(ies) trace(s) a circular path in approximately a horizontal plane. Carving is performed while head-down, head-up or in other orientations.

D-2. Vertical Orbits

The Performer(s) body(ies) trace(s) a circular path in a vertical plane. Eagles and Reverse Eagles are two (2) common forms of Vertical Orbits that involve also rotating about the Body Left-Right Axis.

Eagle

The Performer(s) travel(s) in a Vertical Orbit while continuously leading with the head, passing through the back-down, head-up, belly-down and/or head-down orientation (in that order, if infacing). An Eagle may begin from any orientation in this progression. A Half Eagle is when the Performer has travelled head first through 180° of vertical orbiting. A Full Eagle is when the Performer has travelled head first through 360° of vertical orbiting.

Reverse Eagle

The Performer(s) travel(s) in a Vertical Orbit while continuously leading with the feet (or tail-bone), passing through the back-down, head-down, belly-down and/or head-up orientation (in that order, if infacing). A Reverse Eagle may begin from any orientation in this progression. A Half Reverse Eagle is when the Performer has travelled feet (or tail-bone) first through 180° of vertical orbiting. A Full Reverse Eagle is when the Performer has travelled feet (or tail-bone) first through 360° of vertical orbiting.

ADDENDUM – C DIFFICULTY

'Difficulty' is the combined result of several factors. The overall performance of the Flights (moves, patterns and transitions) counts for difficulty. In general, difficulty factors are:

Easier	More Difficult
High drag moves flown with slow tunnel speed	High drag moves flown with fast tunnel speed, the longer the duration of high drag move(s), the more difficult
Low drag moves flown with fast tunnel speed	Low drag moves flown with slow tunnel speed, the longer the duration of the low drag move(s), the more difficult
Moves executed individually	Moves executed in a connected sequence
Body position lost during move(s)	Ideal body position maintained throughout move(s)
Random Movements	Precisely Choreographed Movements
Move(s)/Pattern(s) without elements of precision	Move(s)/Pattern(s) with elements of precision, e.g., head-to-head with no other grips
Easy natural body positions	Awkward body position and/or grip(s), such as a hand grip on one's own foot with that grip behind
Move(s) do(es) not require flexibility	Move(s) require(s) flexibility
Move(s) do(es) not require strength and power.	Move(s) require(s) strength and power
Basic, simple Move(s)/Pattern(s)	Move(s)/Pattern(s) require(s) long learning progression
Performing previously seen Move(s)/Pattern(s)	Performing brand new Move(s)/Pattern(s)
Rotations on 1 axis	Rotations on more than 1 axis (in which use of 3 axes is more difficult than use of 2 axes)
Slow flying in lose proximity	Fast flying in very close proximity
Performing moves, carving/rotating always in a preferred direction	Performing moves, carving/rotating in both directions
Performer(s) flying in clean airflow	Performer(s) flying across burble of other Performer(s) and/or doorway
Fast transitions through burble(s) of other Performer(s) and/or doorway	Performer(s) remaining in burble(s) of other Performer(s) and/or doorway for extended time
All Performers flying in same direction and pathway (carving, vertical orbiting, etc.)	Performers simultaneously flying different directions and pathways, intermixing (while carving, vertical orbiting, etc.)
Carving/vertical orbits without embedded move(s)	Carving/vertical orbits with embedded move(s)
Transitions between Moves/Patterns with the same axes	Transitions between Moves/Patterns with different axes at a precise heading/orientation
No direction change	Reversal of direction at a precise heading/orientation
Complex Moves/Patterns using arms and legs to control flying	Variety of complex Moves/Patterns without using arms or with arms and/or legs in fixed pose or in creative, artistic gestures
Eye contact with other Performer(s)	No eye contact (blind) with other Performer(s)
Landing on the cable floor to exit and end routine	Landing exactly in the doorway with a complex move to exit and end routine

Combinations of multiple factors further increase difficulty. Teams are not expected to demonstrate all of the above difficulty factors within one routine. A difficulty factor may sometimes have the opposite effect of making a Move/Pattern easier, e.g., retracting the arms keeping them fixed to the body may decrease the difficulty of certain moves. Judges are expected to apply additional knowledge and understanding of difficulty.

This table of difficulty factors only provides examples.

Difficulty Free Routine Moves and Patterns Categorised by Type of Movement					
Type of Move	Very easy	Easy	Moderate	Difficult	Very difficult
HD Inface Carving	Same direction	With direction change	With mixed orientations	With mixed directions	Mixed orientations AND directions
HD Outface Carving		Same direction	With direction change	Mixed orientations OR directions	Mixed orientations AND directions
HU Inface Carving	Same direction	With direction change	With mixed orientations	With mixed directions	Mixed orientations AND directions
HU Outface Carving		Same direction	With direction change	Mixed orientations OR directions	Mixed orientations AND directions
HD Flares	Same direction	With direction change	With mixed orientations	While crossing & burble hopping, mixed directions	While crossing & burble hopping, mixed orientations AND directions
HU Flares	Same direction	With direction change	With mixed orientations	While crossing & burble hopping, mixed directions	While crossing & burble hopping, mixed orientations AND directions
Cheerleaders	Direction change returning to same orientation	Direction change into different orientation	With mixed orientations	Transition into verticals or flares	Transition into verticals or flares with tricks OR spins
Interlacing	Transition into carving	Transition into carving with orientation change	Transition into verticals	Transition into verticals with spins	Transition into verticals with flips/loops
Breakers	Same direction	Mixed direction & crossing with burble hopping	With mixed orientations	Anti-breakers	Anti-breakers with mixed directions & crossing with burble hopping
Back Layouts (Verticals)	Back Layout (V-1)	Verticals while crossing & burble hopping	Back Layout with spins OR tricks		Mixed orientation back layouts with tricks OR spins
Front Layouts (Verticals)		Front Layout (2015 D2W/D4W-10)	Verticals while crossing & burble hopping	Front Layout with spins OR tricks	Mixed orientation Front Layouts with tricks OR spins

The above table shows a scale of difficulty for each type of move/pattern and each type of move/pattern is to be read within its own line. The table does not compare the difficulties of each type of move/pattern to the other types of moves/patterns, e.g., it does NOT intend to imply that a basic Breaker is as easy as basic HD Inface Carving.

Judges are expected to apply additional knowledge and understanding of difficulty.

ADDENDUM - D FREE ROUTINE DESCRIPTION

Instructions for use:

Word file (recommended):

- Download the Addendum – D as word.doc on a PC and save it, preferably under your Team country name and number.
- Fill in the required data.
- Add rows in the Free Routine description if needed.
- When done, save it again under a name relating to your team and event.
- Print the document and deliver it to the Chief Judge.

PDF file:

- Print the page of the Addendum – D.
- Fill in the required data with pen (black or blue only).
- Print the last page with boxes only if you need more space for the Free Routine description.
- When done, deliver it to the Chief Judge.
- ***Do not write out of the boxes, or in the sidelines or edges of the paper.***

Team #	Team Name:
	Tunnel Speed Setting Used:

The Free Routine description covers the following rounds:	
---	--

Name of move / sequence	Description if appropriate

ADDENDUM – E1
TOURNAMENT BRACKET - FOUR (4) TEAMS (para 5.7.1)

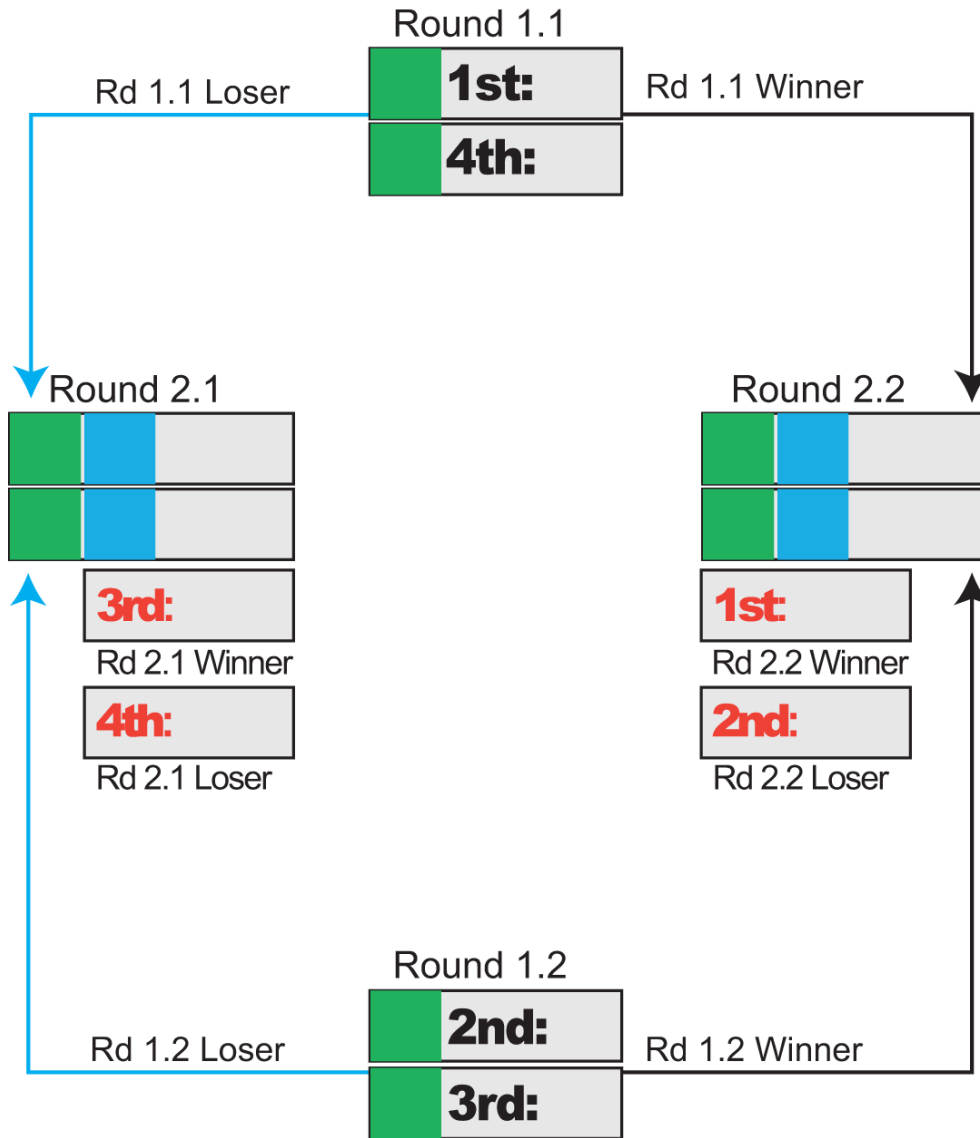

- As Battles are completed, each Team number is written into the grey box of their next Battle.
- Each Team that wins a Battle follows the black line to their next Battle.
- Each Team that loses a Battle follows the blue line to their next Battle.

Legend

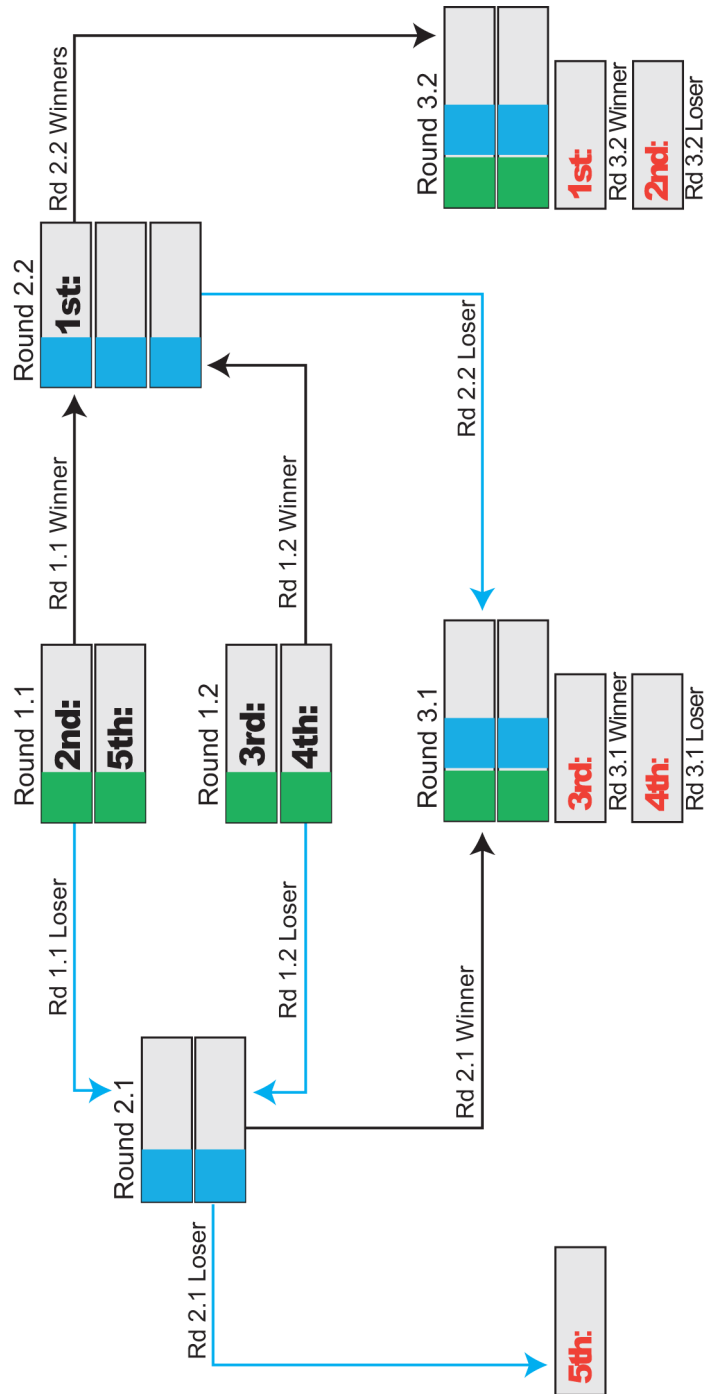

- 1st:** Placing from Qualification Rounds (bold black)
- 1st:** Final Placing (bold red)
- Free Routine (green)
- Speed Routine (blue)

ADDENDUM – E2
TOURNAMENT BRACKET - FIVE (5) TEAMS (para 5.7.1)



- As Battles are completed, each Team number is written into the grey box of their next Battle.
- Each Team that wins a Battle follows the black line to their next Battle.
- The two (2) Teams with the fastest times in Round 2.2 will move to Round 3.2.
- Each Team that loses a Battle follows the blue line to their next Battle.

Legend

1st:	Placing from Qualification Rounds (bold black)		Free Routine (green)
1st	Final Placing (bold red)		Speed Routine (blue)

ADDENDUM – E3
TOURNAMENT BRACKET - SIX (6) TEAMS (para 5.7.1)

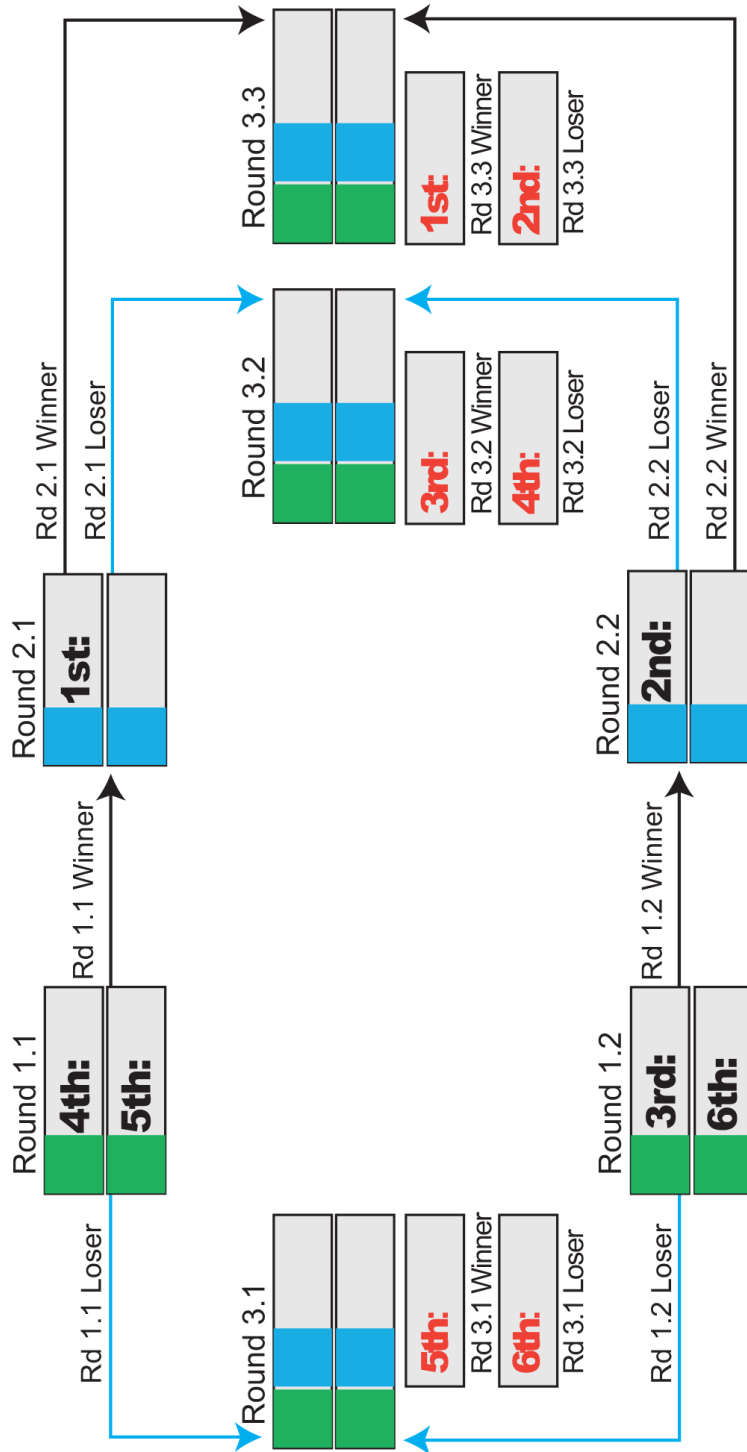

- As Battles are completed, each Team number is written into the grey box of their next Battle.
- Each Team that wins a Battle follows the black line to their next Battle.
- Each Team that loses a Battle follows the blue line to their next Battle.

Legend

1st:	Placing from Qualification Rounds (bold black)	 Free Routine (green)
1st	Final Placing (bold red)	 Speed Routine (blue)

ADDENDUM – E4 TOURNAMENT BRACKET - SEVEN (7) TEAMS (para 5.7.1)

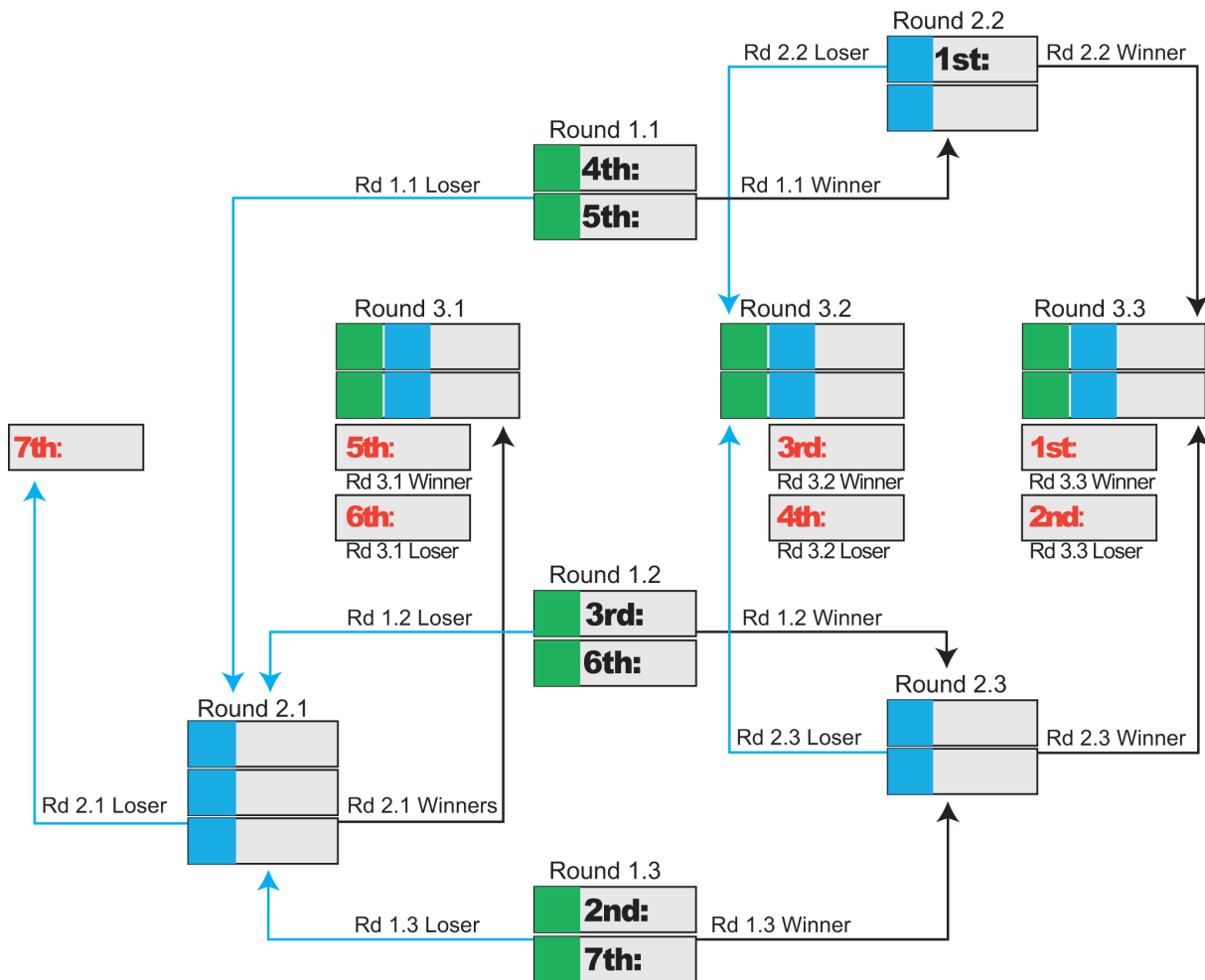

- As Battles are completed, each Team number is written into the grey box of their next Battle.
- Each Team that wins a Battle follows the black line to their next Battle.
- Each Team that loses a Battle follows the blue line to their next Battle.
- The two (2) Teams with the fastest times in Round 2.1 will move to Round 3.1.

Legend

1st:	Placing from Qualification Rounds (bold black)	 Free Routine (green)
1st	Final Placing (bold red)	 Speed Routine (blue)

ADDENDUM – E5 TOURNAMENT BRACKET - EIGHT (8) TEAMS (para 5.7.1)

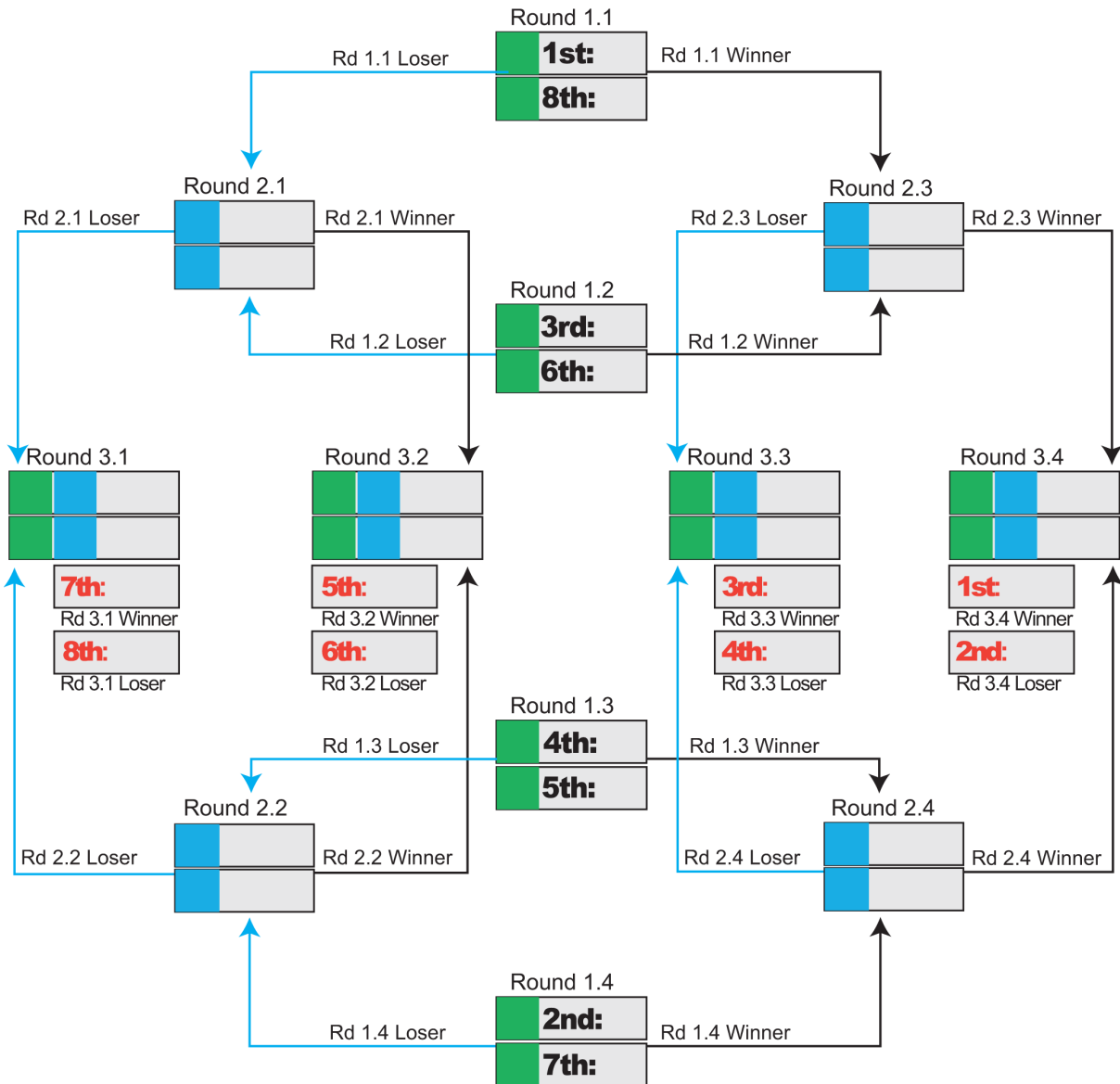

- As Battles are completed, each Team number is written into the grey box of their next Battle.
- Each Team that wins a Battle follows the black line to their next Battle.
- Each Team that loses a Battle follows the blue line to their next Battle.

Legend

1st:	Placing from Qualification Rounds (bold black)	 Free Routine (green)
1st	Final Placing (bold red)	 Speed Routine (blue)

ADDENDUM – E6 TOURNAMENT BRACKET - NINE (9) TEAMS (para 5.7.1)

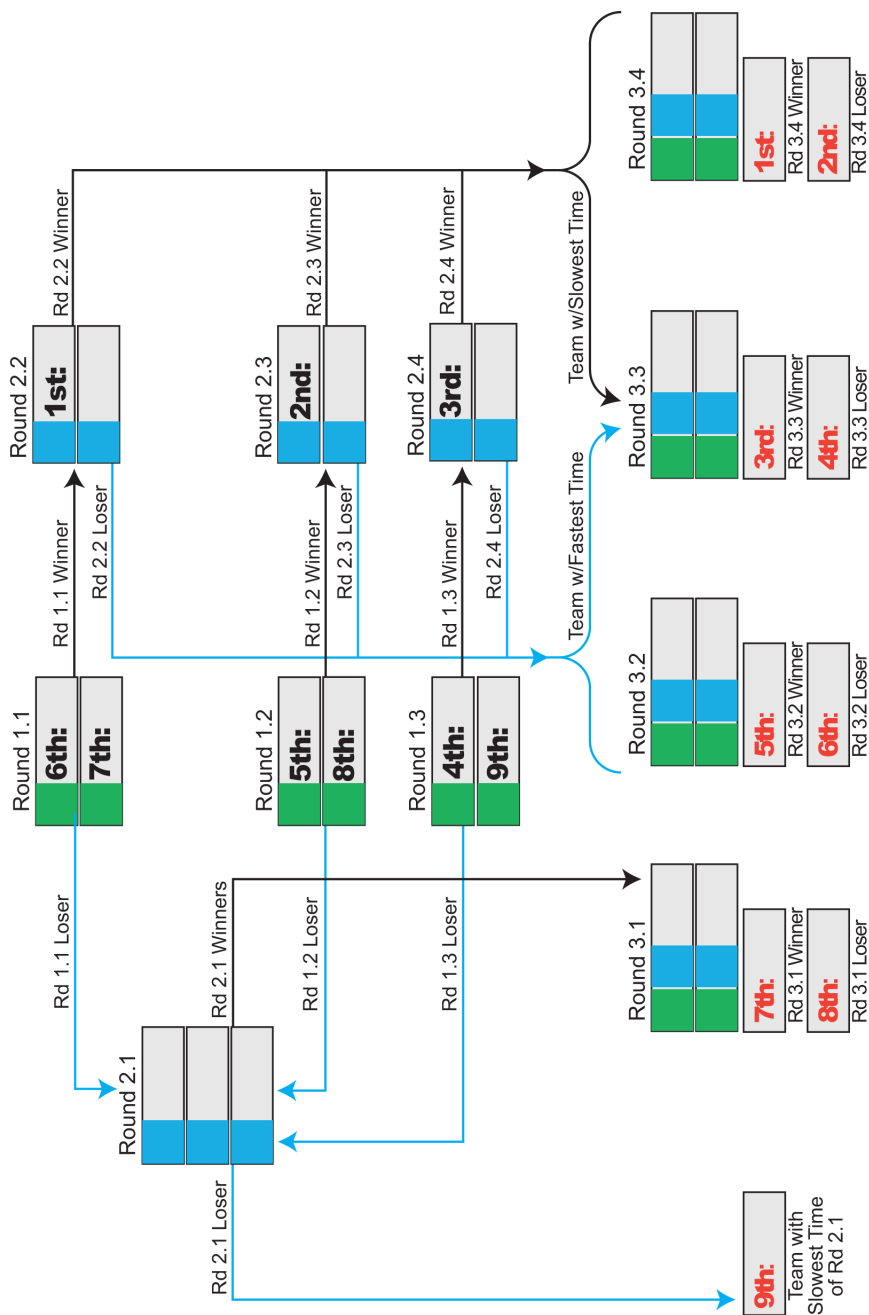

- As Battles are completed, each Team number is written into the grey box of their next Battle.
- Each Team that wins a Battle follows the black line to their next Battle.
- Each Team that loses a Battle follows the blue line to their next Battle.
- The two (2) Teams with the fastest times in Round 2.1 will move to Round 3.1.
- Among the losers of rounds 2.2 to 2.4, the Team with the fastest time will move to round 3.3 and the other two (2) Teams will move to round 3.2.
- Among the winners of rounds 2.2 to 2.4, the Team with the slowest time will move to round 3.3 and the other two (2) Teams will move to round 3.4.

Legend

1st:	Placing from Qualification Rounds (bold black)	 Free Routine (green)
1st	Final Placing (bold red)	 Speed Routine (blue)

ADDENDUM – E7 TOURNAMENT BRACKET - TEN (10) TEAMS (para 5.7.1)

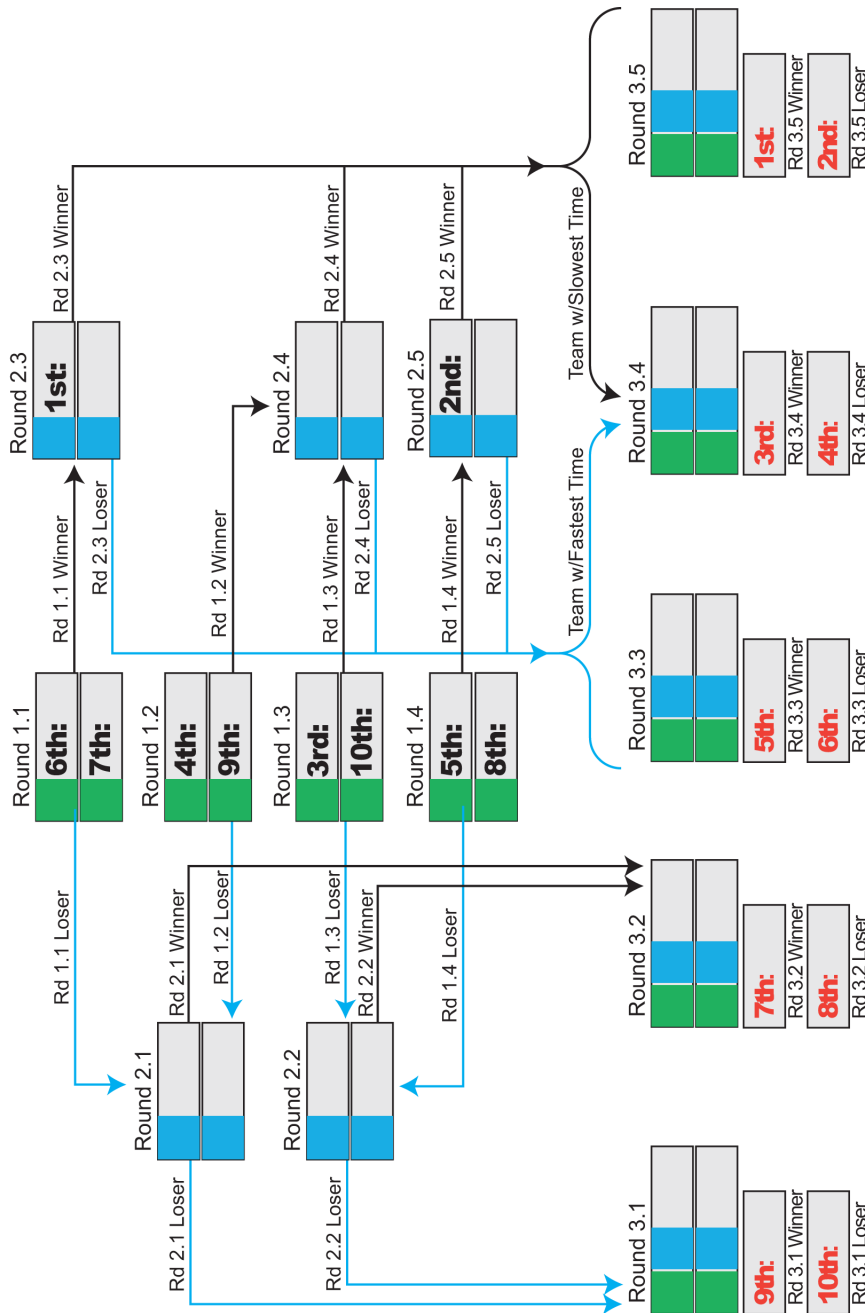

- As Battles are completed, each Team number is written into the grey box of their next Battle.
- Each Team that wins a Battle follows the black line to their next Battle.
- Each Team that loses a Battle follows the blue line to their next Battle.
- Among the losers of rounds 2.3 to 2.5, the Team with the fastest time will move to round 3.4 and the other two (2) Teams will move to round 3.3.
- Among the winners of rounds 2.3 to 2.5, the Team with the slowest time will move to round 3.4 and the other two (2) Teams will move to round 3.5.

Legend

1st:	Placing from Qualification Rounds (bold black)	 Free Routine (green)
1st	Final Placing (bold red)	 Speed Routine (blue)

ADDENDUM – E8 TOURNAMENT BRACKET - ELEVEN (11) TEAMS (para 5.7.1)

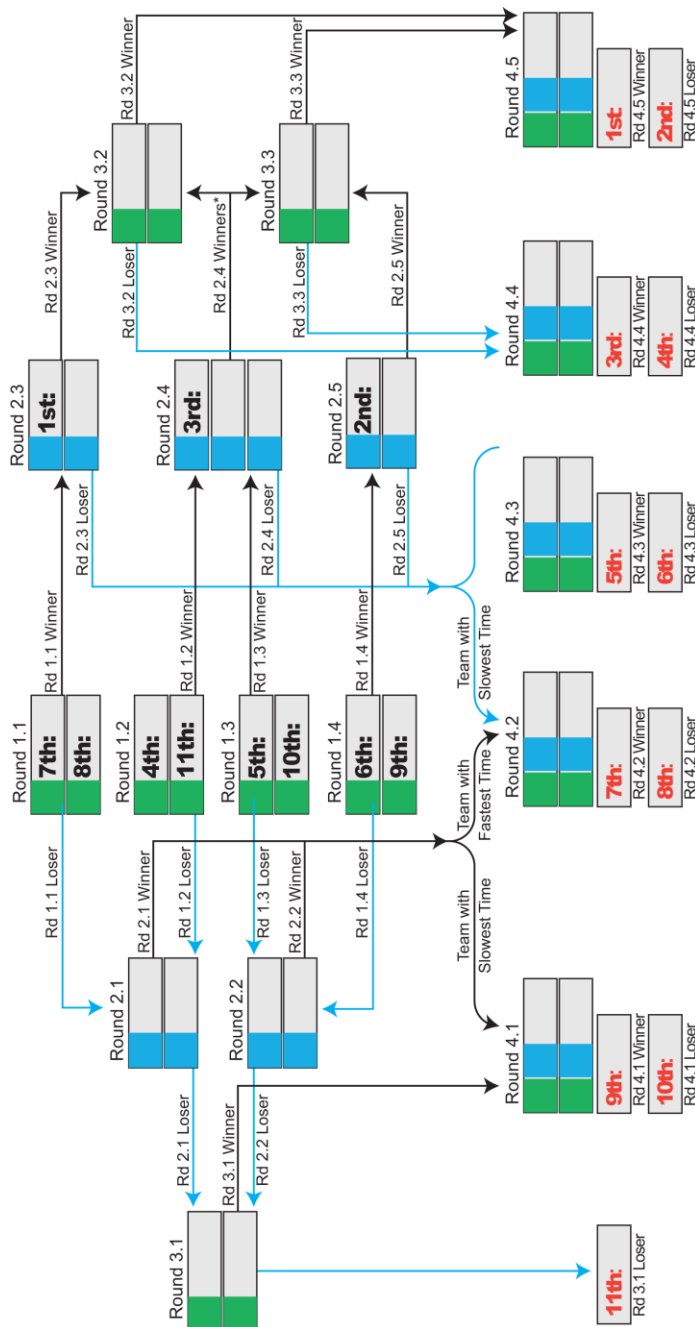

- As Battles are completed, each Team number is written into the grey box of their next Battle.
- Each Team that wins a Battle follows the black line to their next Battle.
- Each Team that loses a Battle follows the blue line to their next Battle.
- Among the winners of rounds 2.1 and 2.2, the Team with the fastest time will move to round 4.2 and the Team with the slowest time will move to round 4.1.
- Among the three (3) losers of rounds 2.3 to 2.5, the Team with the slowest time will move to round 4.2 and the other two (2) Teams will move to round 4.3.
- Of the two (2) Teams with the fastest times in Round 2.4, by random determination*, one Team will move to Round 3.2. and the other Team will move to Round 3.3.

Legend

1st: Placing from Qualification Rounds (bold black) Free Routine (green)

1st

Final Placing (bold red)



Speed Routine (blue)

ADDENDUM – E9 TOURNAMENT BRACKET - TWELVE (12) TEAMS (para 5.7.1)

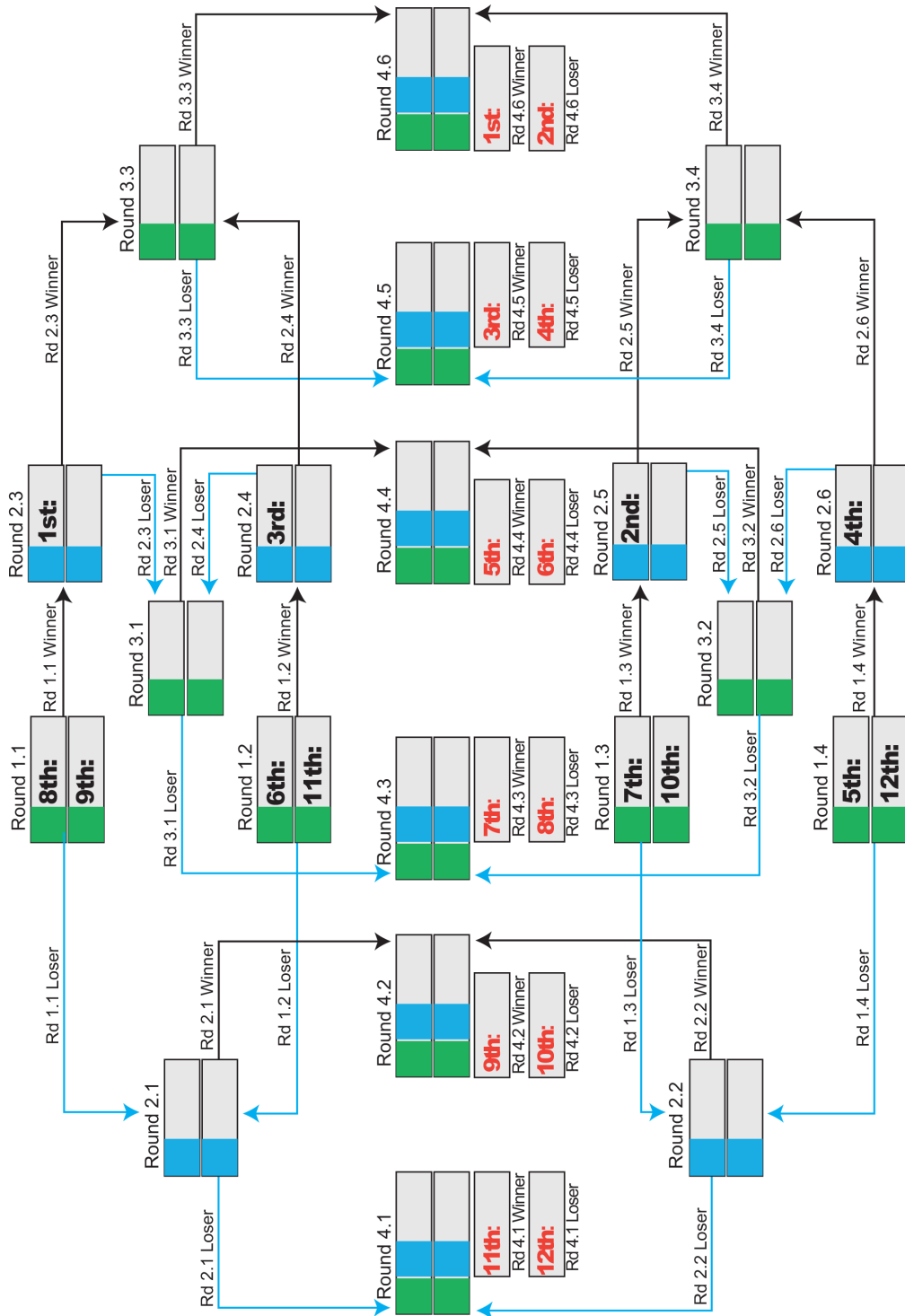

- As Battles are completed, each Team number is written into the grey box of their next Battle.
- Each Team that wins a Battle follows the black line to their next Battle.
- Each Team that loses a Battle follows the blue line to their next Battle.

Legend

1st:	Placing from Qualification Rounds (bold black)	 Free Routine (green)
1st	Final Placing (bold red)	 Speed Routine (blue)

ADDENDUM – E10 TOURNAMENT BRACKET - THIRTEEN (13) TEAMS (para 5.7.1)

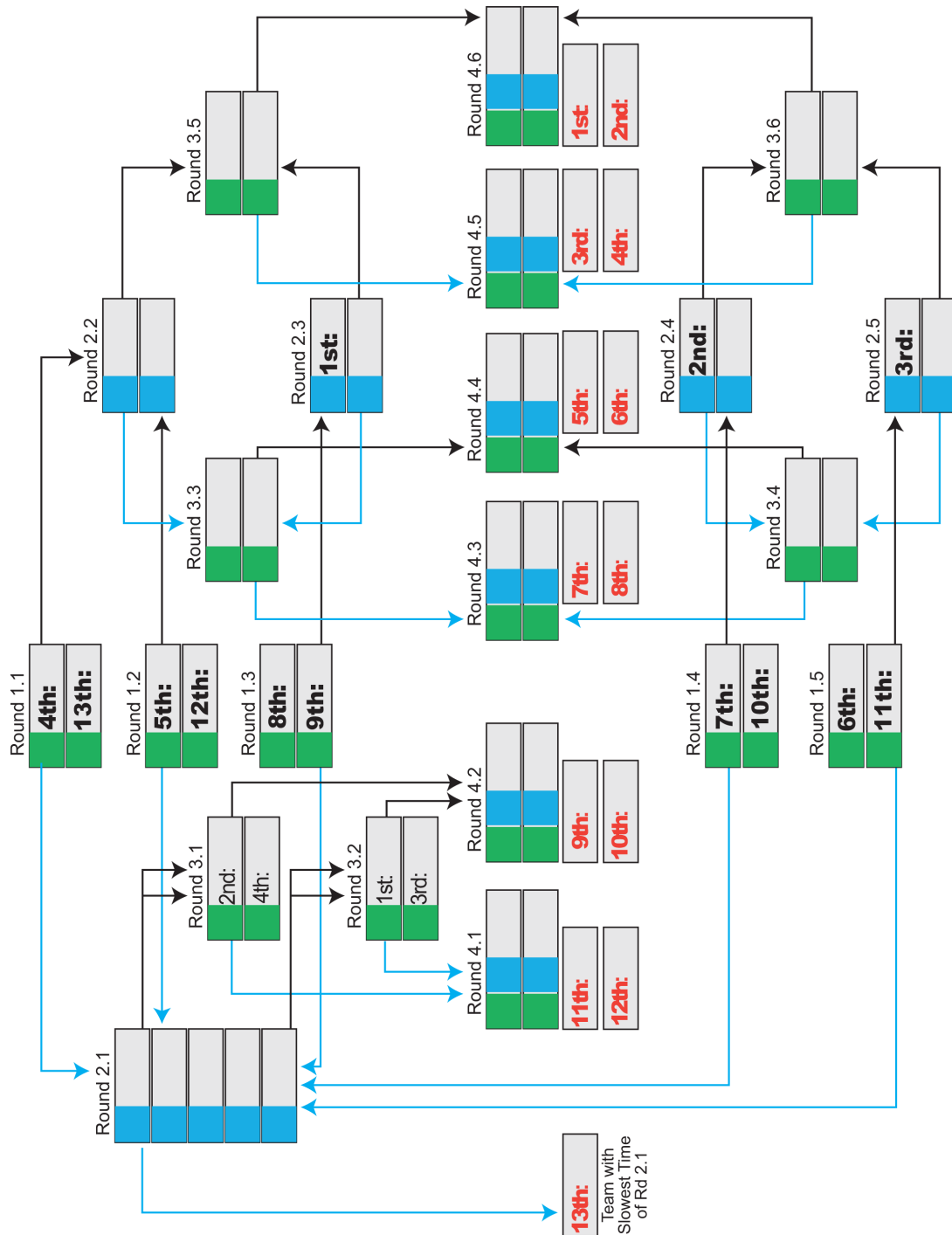

- As Battles are completed, each Team number is written into the grey box of their next Battle.
- Each Team that wins a Battle follows the black line to their next Battle.
- Each Team that loses a Battle follows the blue line to their next Battle.
- The Teams with the second and fourth fastest time in round 2.1 will move to round 3.1.
- The Teams with the fastest and third fastest time in round 2.1 will move to round 3.2.
- The Team with the slowest time in round 2.1 will be 13th place.

Legend

1st:	Placing from Qualification Rounds (bold black)	 Free Routine (green)
1st	Final Placing (bold red)	 Speed Routine (blue)

ADDENDUM – E11 TOURNAMENT BRACKET - FOURTEEN (14) TEAMS (para 5.7.1)

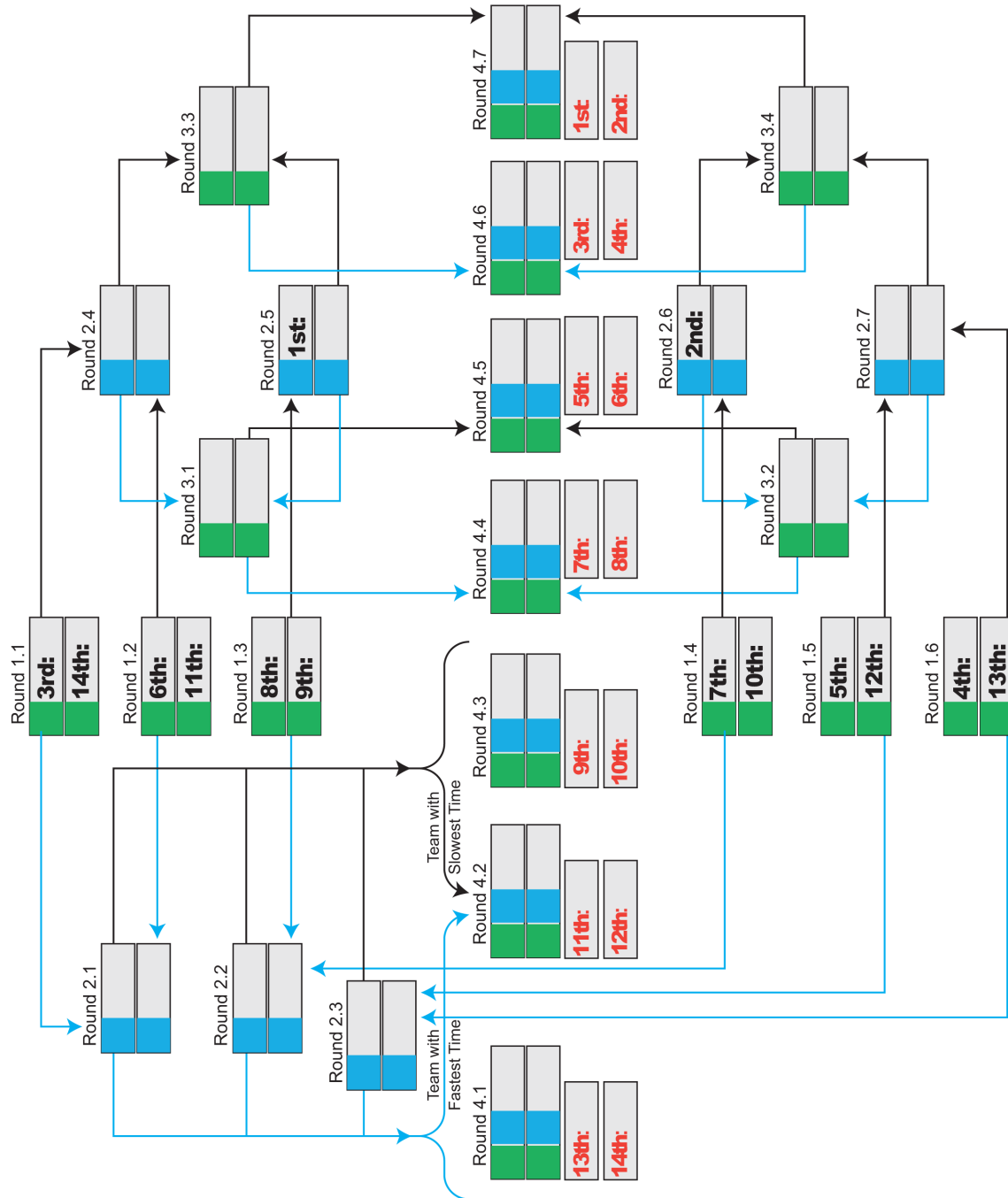

- As Battles are completed, each Team number is written into the grey box of their next Battle.
- Each Team that wins a Battle follows the black line to their next Battle.
- Each Team that loses a Battle follows the blue line to their next Battle.
- Among the three (3) losers of rounds 2.1 to 2.3, the Team with the fastest time will move to round 4.2 and the other two (2) Teams will move to round 4.1.
- Among the three (3) winners of rounds 2.1 to 2.3, the Team with the slowest time will move to round 4.2 and the other two (2) Teams will move to round 4.3.

Legend

1st:	Placing from Qualification Rounds (bold black)	 Free Routine (green)
1st	Final Placing (bold red)	 Speed Routine (blue)

ADDENDUM – E12 TOURNAMENT BRACKET - FIFTEEN (15) TEAMS (para 5.7.1)

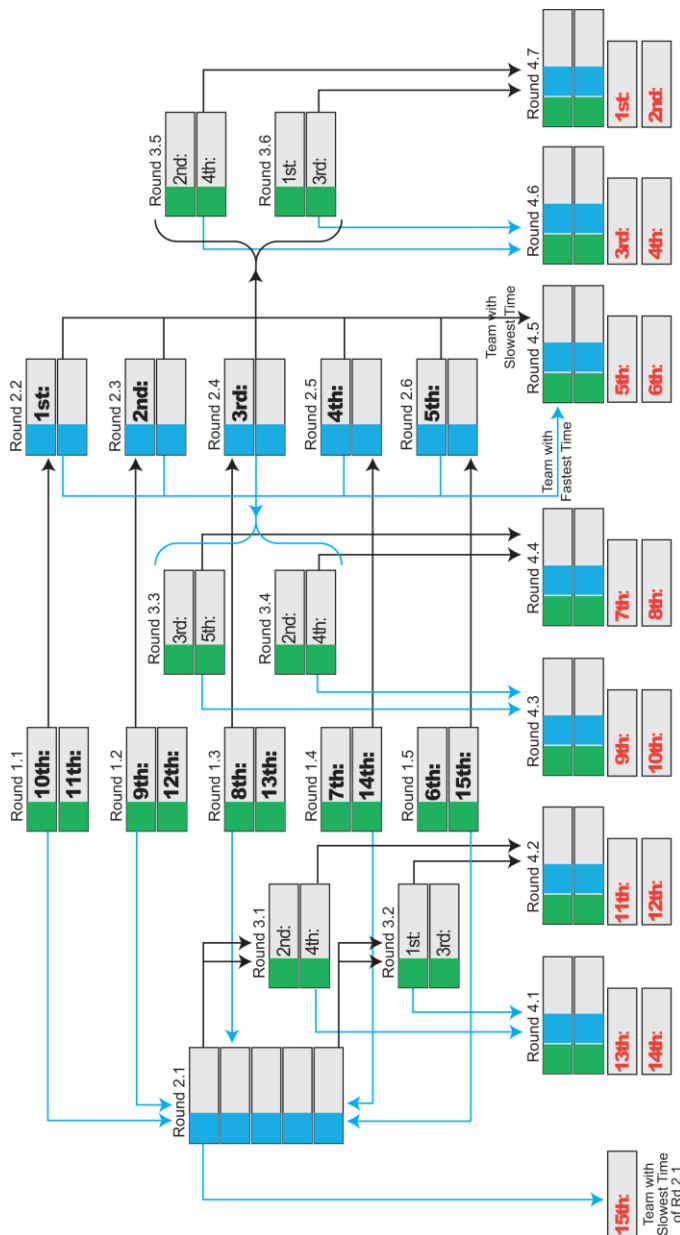

- As Battles are completed, each Team number is written into the grey box of their next Battle.
- Each Team that wins a Battle follows the black line to their next Battle.
- Each Team that loses a Battle follows the blue line to their next Battle.
- The Team with the second and fourth fastest time in round 2.1 will move to round 3.1.
- The Teams with the fastest and third fastest time in round 2.1 will move to round 3.2.
- The Team with the slowest time in round 2.1 will be 15th place.
- Among the losers of rounds 2.2 to 2.6, the Team with the fastest time will move to round 4.5, the Teams with the third and fifth fastest time will move to round 3.3, and the Teams with the second and fourth fastest time will move to round 3.4.
- Among the winners of rounds 2.2 to 2.6, the Team with the slowest time will move to round 4.5, the Teams with the second and fourth fastest time will move to round 3.5, and the Teams with the fastest and third fastest time will move to round 3.6.

Legend

1st: Placing from Qualification Rounds (bold black) Free Routine (green)

1st

Final Placing (bold red)



Speed Routine (blue)

ADDENDUM – E13

TOURNAMENT BRACKET - SIXTEEN (16) to EIGHTEEN (18) TEAMS (para 5.7.1)

- If there are 17 Teams, the last two (2) Teams from the Qualifying rounds will fly a Speed Routine.
- If there are 18 Teams, the last three (3) Teams from the Qualifying rounds will fly a Speed Routine.
- The Team with the fastest time will be in Round 1.1 in the Tournament Bracket.

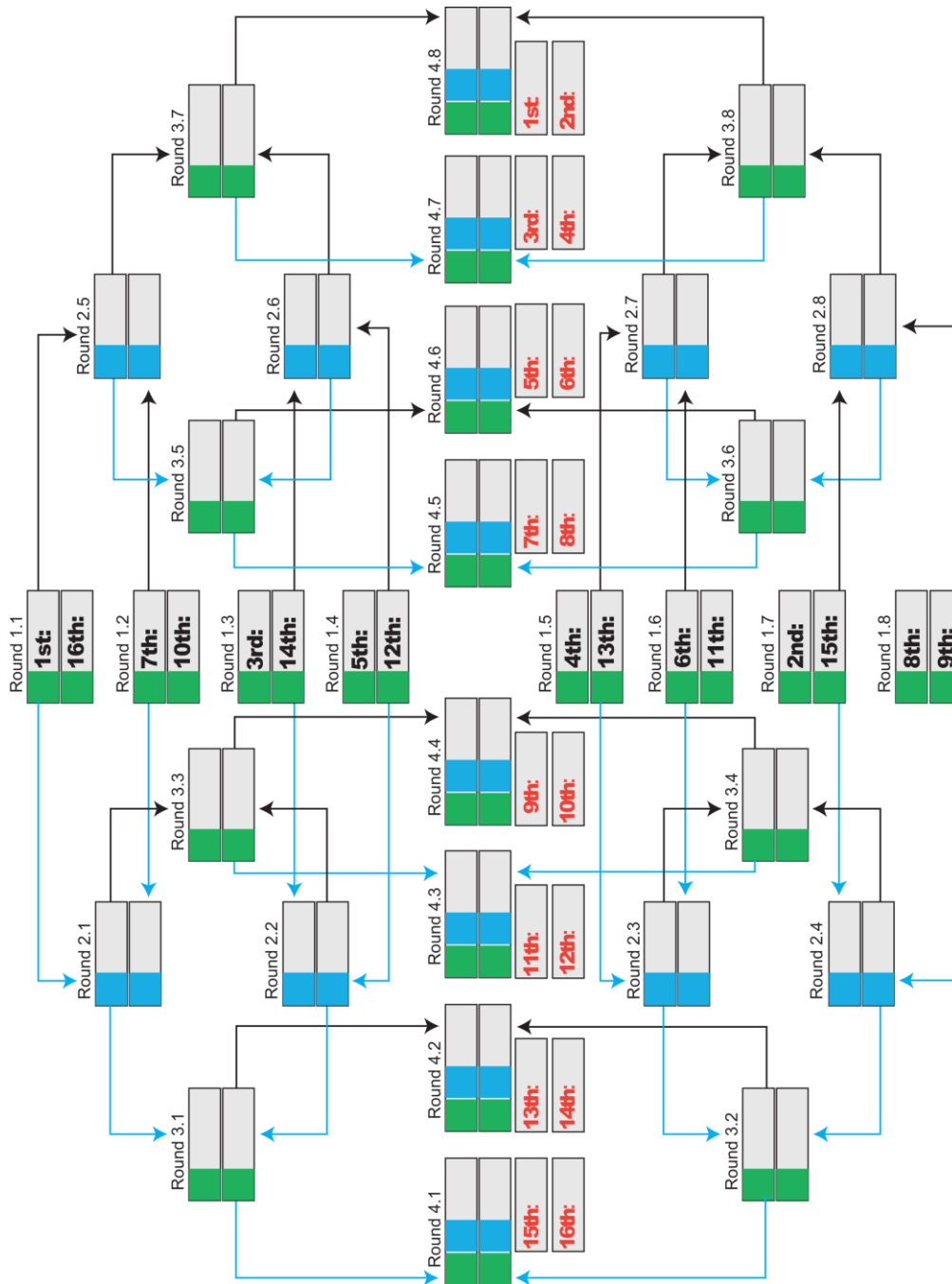

- As Battles are completed, each Team number is written into the grey box of their next Battle.
- Each Team that wins a Battle follows the black line to their next Battle.
- Each Team that loses a Battle follows the blue line to their next Battle.

Legend

1st:	Placing from Qualification Rounds (bold black)	 Free Routine (green)
1st:	Final Placing (bold red)	 Speed Routine (blue)

ADDENDUM – E14 TOURNAMENT BRACKET - NINETEEN (19) to THIRTY-TWO (32) TEAMS (para 5.7.1)

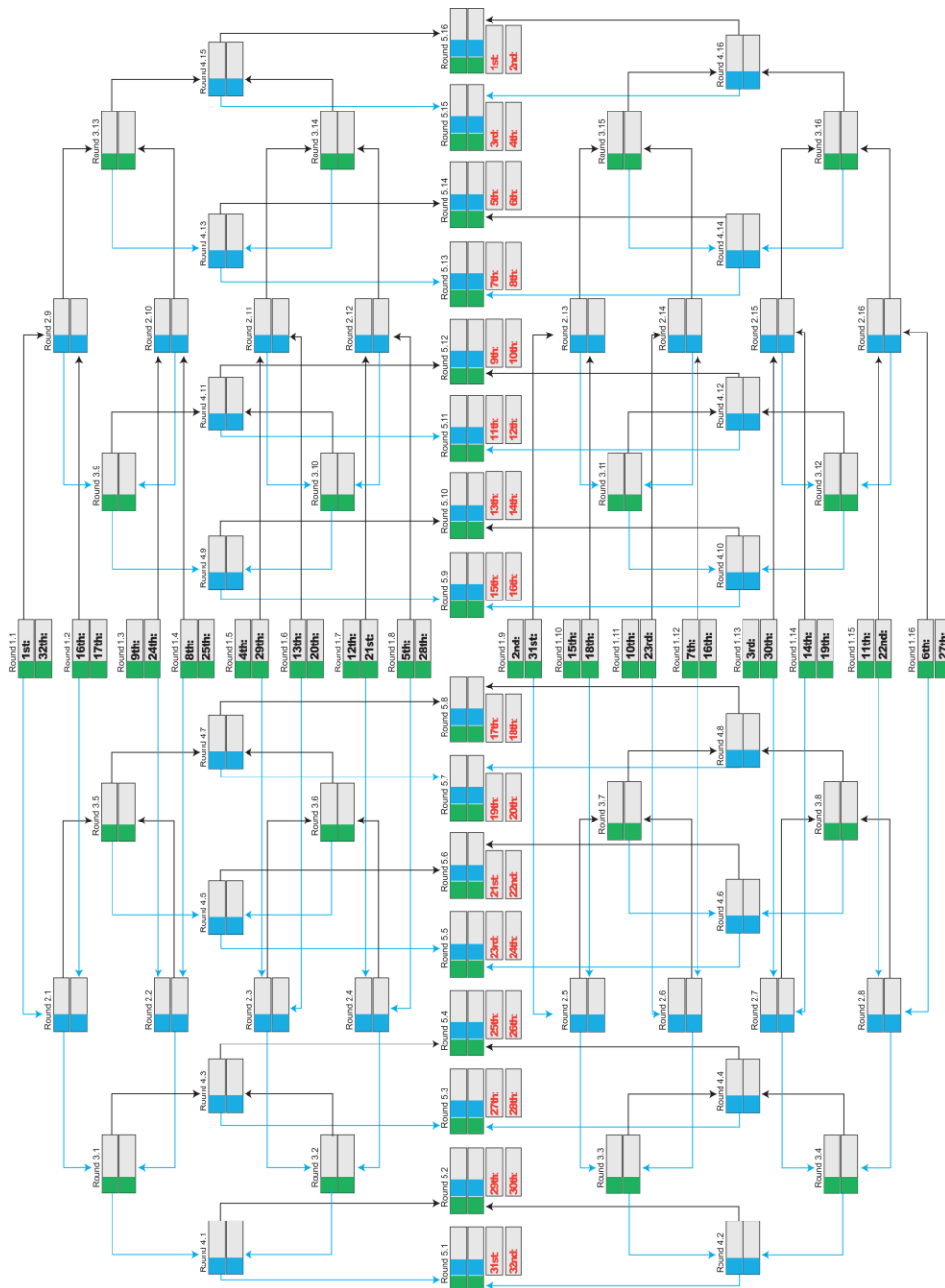

- As Battles are completed, each Team number is written into the grey box of their next Battle.
- Each Team that wins a Battle follows the black line to their next Battle.
- Each Team that loses a Battle follows the blue line to their next Battle.
- Whenever a Team is not battling another Team in a Battle, the Team automatically follows the black line to their next Battle.

Legend

1st:	Placing from Qualification Rounds (bold black)	 Free Routine (green)
1st	Final Placing (bold red)	 Speed Routine (blue)